



allweatherinc

Micro Response Wind Sensors Models 2020 & 2030

MicroResponse Wind Vane

Description

This is a highly reliable, low threshold wind direction sensor. It responds to winds as low as 0.5 MPH. The machined aluminum body is aerodynamically shaped to combat sensor-induced turbulence. A labyrinth beneath the vane assembly prevents water and dust particles from reaching the sealed bearings at the top of the shaft. The reinforced, lightweight foam tail has a butyrate skin and a stainless steel counterweight.

Features

As the vane turns, it rotates a stainless steel shaft held in place with instrument-grade bearings. A waterproof conductive plastic potentiometer is coupled to the base of the shaft. This potentiometer has excellent linearity. Very low torque (0.15 inch ounces) is required to move the wiper. The use of a single wiper doubles the life expectancy of the potentiometer compared to dual-wiper potentiometers. Electronic switching inside the signal conditioning module provides an output range of 0° to 360°.

Mounting

The Model 2023 cross arm is recommended for mounting the micro response vane in conjunction with the micro response anemometer. A mast adapter is available for mounting either sensor alone on a 1-inch 25 mm O.D. mast. Fixed keying of the sensor bodies makes orientation necessary one time only.

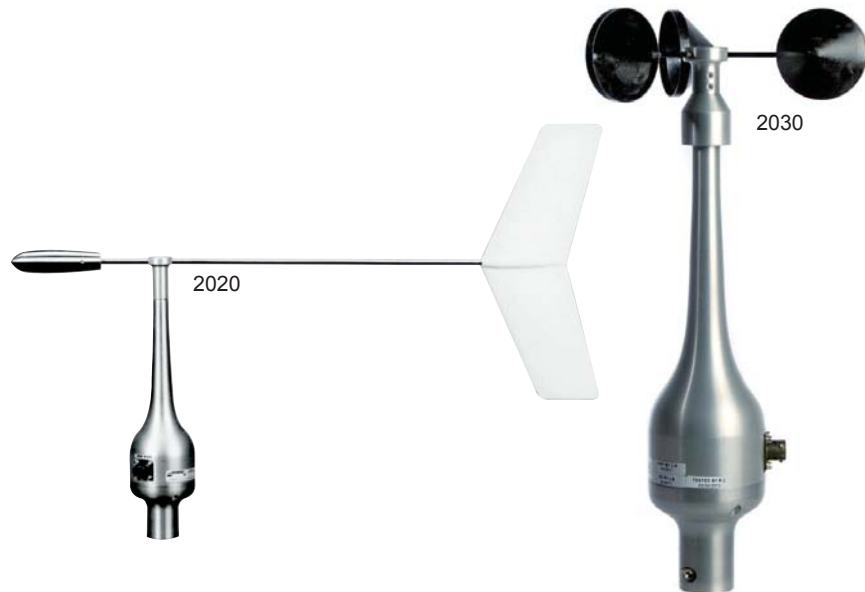

MicroResponse Anemometer Description

This is a highly responsive and rugged 3-cup anemometer designed to measure very low wind speeds (0.5 mph threshold). It is constructed entirely of stainless steel and anodized aluminum to resist corrosive environments. Like its vane counterpart, the micro response anemometer has an aerodynamically shaped body and utilizes a labyrinth to prevent dust and water from reaching the bearings.

Rotation of the main shaft by the cup assembly moves a slotted disc through a photon beam, which is generated by a long-life infrared LED. The interruption of the beam causes a pulse output with a frequency proportional to wind speed. The photon-coupled chopper is mounted on the connector and can be removed from the body simply by removing the connector.

Two Models

In addition to the Model 2030, AWI offers a second micro response anemometer that is similar in construction but utilizes a different transducer. The Model 2031 uses a DC generator to produce a DC voltage proportional to wind speed. The main shaft couples the cup assembly directly to the generator. Output is approximately 5.5 mV/mph.

Heaters

Optional heaters are available for use in cold climates to minimize freezing of vane and anemometer shafts. The heater assembly, Model 20201, mounts between the top and bottom sections of the sensor body. It consists of a solid block of aluminum with a machined cavity containing a 20-watt heater. The block acts as a heat sink, and the heater raises the block's temperature 20°C above the ambient temperature. Environmental connectors are supplied with the heater. An optional thermostat is available.

SENSORS

2020 SPECIFICATIONS

Parameter	Specification
Sensor Type	Counter-balanced Tail
Transducer	Potentiometer, 5000 Ω , single wiper
Excitation	5 V DC, 1 mA
Range	0 - 360 °
Threshold	0.5 mph (0.2 m/s)
Potentiometer Linearity	0.5%
Accuracy	$\pm 2^\circ$, 5° deadband at 0°
Resolution	<1.0°
Delay Distance	3.5 ft (1.1 m)
Damping Ratio	0.4
Bearing	Sealed dry stainless steel bearing w/synthetic lubricant
Operating Temp. Range	-40°C to +60°C
Turning Radius	18" (457 mm)
Mounting	Direct to crossarm or w/adapter to 1" (25 mm) O.D. mast

2030/2031 SPECIFICATIONS

Parameter	Specification
Sensor Type	3-cup assembly, carbon graphite composite, 2" diameter cups
Transducer	2030 - Light Chopper 2031 - DC Generator
Excitation (2030)	12 V DC, 25 mA
Light Source (2030)	LED
Output (2030)	30 pulses/rev, 900 Hz @ 88.8 mph
Output (2031)	7 mV/mph
Shaft Torque (2031)	0.05–0.06 oz/inch
Range	0–160 mph (0–75 m/s)
Threshold	0.5 mph (0.2 m/s)
Accuracy	$\pm 1^\circ$ (± 0.15 mph)
Delay Distance	5 ft (1.5 m)
Materials	Stainless steel and anodized aluminum
Operating Temp. Range	-40°C to +60°C
Turning Radius	3.8" (97 mm)
Mounting	Direct to crossarm or w/adapter to 1" (25 mm) O.D. mast

ORDERING INFORMATION

Part Number	Description
2020	Micro Response Vane
20201	Sensor Heater Assembly, 115 Vac
20201-A	Sensor Heater Assembly, 230 Vac
10681	Thermostat Control for Sensor Heater
T600503	Heater Cable, 3-conductor, 20 AWG
T802000	Tail Vane
T800301	Counterweight
T800801-01	Vane Hub
T170522	Pot/Shaft Assembly
2030	Micro Response Anemometer
2031	Micro Response Anemometer (DC)
T800303-01	Cup Assembly
T801600	Light Chopper Assembly
T600502	Cable, 2-conductor, 20 AWG shielded for 2031
T600504	Cable, 4-conductor, 20 AWG shielded for 2030
2023	Crossarm for mounting 2 micro response wind sensors to 1" (25 mm) mast.
20231	Mast adapter to mount 1 micro response wind sensor to a 1" (25 mm) mast.
20206	2020 Cable (50')
20306	2030 Cable (50')
M488140	Spare Parts Kit for 2020
M488141	Spare Parts Kit for 2030

DIMENSIONS & WEIGHTS

2020/2030 Body Size	12" high x 2.75" Diameter (305 x 70 mm)
2020/2030 Body Weight	2.5 lbs (1.1 kg)
20201 Dimensions	1.5" x 2.64" (38 x 67 mm)
20201 Product Weight	1 lb (0.4 kg)

SHIPPING INFORMATION

2020 Dimensions	
2020 Shipping Weight	
2030 Dimensions	
2030 Shipping Weight	



All Weather Inc.
1165 National Dr.
Sacramento, CA 95834

Phone: 916-928-1000
USA Toll Free: 800-824-5873
Fax: 916-928-1165

www.allweatherinc.com

Rev. A 04/2011