



**DEPARTMENT OF TRANSPORTATION
FEDERAL AVIATION ADMINISTRATION**

SYSTEM SPECIFICATION

**AUTOMATED WEATHER SENSORS SYSTEM
(AWSS)**

DISTRIBUTION STATEMENT A. Approved for public release; distribution is unlimited.

TABLE OF CONTENTS

1. SCOPE 1

 1.1 IDENTIFICATION 1

 1.2 SCOPE OF SPECIFICATION 1

 1.3 APPLICATION 1

2. APPLICABLE DOCUMENTS 1

 2.1 GOVERNMENT DOCUMENTS 1

 2.2.1 *Specifications, standards, and handbooks* 1

3. FUNCTIONAL REQUIREMENTS 3

 3.1 INTRODUCTION 3

 3.2 SYSTEM CHARACTERISTICS 3

 3.2.1 *System Description* 3

 3.2.2 *Sensors* 4

 3.3 PERFORMANCE REQUIREMENTS 5

 3.3.1 *Wind Speed and Direction Sensors* 5

 3.3.2 *Temperature and Relative Humidity Sensor* 6

 3.3.3 *Pressure Sensor* 6

 3.3.4 *Visibility Sensor* 7

 3.3.5 *Ceilometer* 8

 3.3.6 *Liquid Precipitation Accumulation Sensor* 9

 3.3.7 *Freezing Rain Occurrence Sensor* 9

 3.3.8 *Precipitation Identification Sensor* 9

 3.3.9 *Lightning and Thunderstorm Reporting* 10

 3.4 ENVIRONMENTAL LIMITS 10

 3.4.1 *Site Elevation* 10

 3.4.2 *Equipment Installed Indoors in a Conditioned Space* 10

 3.4.3 *Equipment Installed Outdoors* 11

 3.4.4 *Electromagnetic Interference* 11

 3.5 RELIABILITY, MAINTAINABILITY, AND AVAILABILITY REQUIREMENTS 12

 3.5.1 *Mean Time to Repair (MTTR)* 12

 3.5.2 *Preventive Maintenance* 12

 3.5.3 *Operational Availability Requirements* 12

 3.5.4 *System Critical Failure/Error Rate Requirements* 13

 3.5.5 *Data Quality Requirements* 14

 3.5.6 *System Diagnostic Capability* 15

 3.6 FIELD DATA COLLECTION UNIT (FDCU) 16

 3.6.1 *Data Sources* 16

 3.6.2 *FDCU Timing and Control* 17

 3.6.3 *FDCU Data Acquisition and Signal Conditioning* 17

 3.6.4 *FDCU Data Communications* 18

 3.6.5 *RF Equipment Location* 18

 3.6.6 *FDCU Power Control and Distribution* 18

3.7 TERMINAL DATA ACQUISITION UNIT (TDAU) 19

 3.7.1 Functional requirements 19

 3.7.2 OID requirements..... 19

 3.7.3 Timing requirements..... 19

 3.7.4 TDAU Timing and Control Functions..... 20

 3.7.5 System Clock..... 20

 3.7.6 TDAU Data Acquisition and Communications 21

 3.7.7 Data Processing 22

 3.7.8 Data Formatting and Archival..... 24

 3.7.9 Data Quality..... 24

 3.7.10 TDAU Power Control and Distribution 25

 3.7.11 TDAU/Peripheral interface requirements..... 26

3.8 OPERATOR INTERFACES 26

 3.8.1 OID Requirements..... 26

 3.8.2 OID signed on functional requirements 29

 3.8.3 OID Interface additional requirements..... 36

3.9 VIDEO DISPLAY UNITS (VDU)..... 40

3.10 EXTERNAL COMMUNICATION INTERFACES 40

 3.10.1 General Requirements..... 40

 3.10.2 Telephone Interfaces 41

 3.10.3 OID Port 42

 3.10.4 Local VDU Port..... 42

 3.10.5 FAA-Digitized Voice/Radio/Telephone/Speaker & Microphone..... 43

 3.10.6 Voice generator interfaces requirements 44

 3.10.7 Automated/manual voice balance output requirements..... 44

 3.10.8 FAA ADAS..... 44

 3.10.9 Remote OID Port 45

 3.10.10 NGRVR Interface..... 45

 3.10.11 ACE-IDS Interface..... 45

 3.10.12 Other Ports..... 45

 3.10.13 Ground to Air Radios 46

3.11 HARDWARE DESIGN AND CONSTRUCTION..... 50

 3.11.1 Uninterruptible Power Supply (UPS)..... 50

 3.11.2 Special Packaging and Housing Considerations 51

 3.11.3 LRU definition 51

 3.11.4 Outdoor Enclosures/Raceways..... 52

 3.11.5 Safety Criteria - Personnel Hazards 52

 3.11.6 Sensor Mounts and Towers 53

 3.11.7 Wind Tower Marking and Lights..... 53

 3.11.8 Electrical Overload Protection 53

 3.11.9 Personnel Hazards 54

 3.11.10 Grounding..... 55

 3.11.11 Bonding..... 55

 3.11.12 Shielding 55

 3.11.13 Flammable Materials 55

 3.11.14 Moisture and Fungus..... 55

3.11.15	<i>Soldering</i>	56
3.11.16	<i>Electrical Overload Protection</i>	56
3.11.17	<i>Electrical Connectors</i>	56
3.11.18	<i>Occupational Safety and Health Administration (OSHA)</i>	56
3.11.19	<i>Maintenance Monitoring Capability</i>	56
3.11.20	<i>Maintenance Data Format and Storage</i>	57
3.11.21	<i>Communications Status Log</i>	57
4.	VERIFICATION	58
4.1	GENERAL.....	58
4.2	RESPONSIBILITY FOR VERIFICATION	58
4.3	VERIFICATION METHOD	58
4.4	VERIFICATION PROGRAM.....	59
5.0	PACKAGING	59
6.0	NOTES	59
6.1	INTENDED USE.....	59
6.2	ACQUISITION REQUIREMENTS.....	59
6.3	ASSOCIATED DATA ITEM DESCRIPTIONS (DIDS)	60
6.4	TECHNICAL MANUALS	60
APPENDIX A	61

List of Figures

Figure 3.2.1-1	AWSS Block Diagram.....	4
Figure 3.10.1-1	Functional Configuration – TDAU Communication Ports	41
Figure 3.10.3-1	Functional Configuration – TDAU OID Cabling	42

List of Tables

Table 3.3.4-1	Sensor Accuracy Table (% of all data)	7
Table 3.5.3-1	AWSS Operational Availability (A _O) Requirements	13
Table 3.8.3.2-1	OID Hot Keys for ATC User	37

1. SCOPE

1.1 Identification

This specification established the functional and performance requirements for the Automated Weather Sensor System (AWSS).

1.2 Scope of Specification

This document is divided into six (6) sections. Section 1 provides an introduction to the AWSS. Section 2 lists those documents referenced within this specification that are needed to meet requirements. Section 3 provides a description of the functional and performance requirements. Section 4 provides a set of qualification methods to ensure that each requirement in Section 3 has been satisfied. Section 5 provides packaging requirements. Section 6 contains information of a general or explanatory nature.

1.3 Application

The mission of the Federal Aviation Administration (FAA) includes the central objective of providing for the safe and efficient use of the national airspace. To accomplish this objective, the National Airspace System (NAS) requires direct aviation meteorological services to support aircraft operations under varying conditions of weather and emergency situations. This document is a compilation of specification that describes the surface weather observation capabilities of an Automated Weather Sensor System (AWSS) for the NAS. It is intended for use as a system specification and as a management tool for engineering and acquisition activities associated with this procurement.

2. APPLICABLE DOCUMENTS

The documents listed in this section are specified in sections 3 and 4 of this specification. This section does not include documents in other sections of this specification or recommended for additional information or as examples. While every effort has been expended to ensure the completeness of this list, document users are cautioned that they must meet all specified requirements documents cited in sections 3 and 4 of this specification, whether or not they are listed.

2.1 Government Documents

2.1.1 Specifications, standards, and handbooks

The following specifications, standards, and handbooks form a part of this document to the extent specified herein. Unless otherwise specified, the issues of these documents are those in effect on the release date of this specification.

FEDERAL

FCM-H1-1998	Federal Meteorological Handbook (FMH-1) - Surface Weather Observations and Reports
ANSI-Z-1136.1	Accessibility Emission Limits For Laser Radiation Class 3B (Current Revision)
ANSI/J-STD-001	Requirements for Soldered Electrical and Electronics Assemblies (Current Revision)

DEPARTMENT OF DEFENSE

MIL-C-26482	General Specification for Connectors, Electrical, (Circular, Miniature, Quick Disconnect, Environment Resisting), Receptacles and Plugs
MIL-STD-461	Measurement of Electromagnetic Interference Characteristics (Current Revision)
MIL-STD-2073	Standard Practice for Military Packaging (Current Revision)

FEDERAL AVIATION ADMINISTRATION

AC 70/7406-1	Specification for Obstruction, Marking & Lighting (Current Revision)
FAA-C-1217	Electrical work, Interior (Exception for AWSS systems manufactured prior to 30 September 2003) (Current Revision)
FAA-STD-19	Lightning and surge protection, grounding, bonding and shielding requirements for facilities and electronic equipment (Exception for AWSS systems manufactured prior to 30 September 2003) (Current Revision)
FAA-STD-20	Transient Protection, Grounding, Bonding & Shielding Requirements for Facilities (Current Revision)
AC 150/5220-16	Automated Weather Observing System (AWOS) For Non-Federal Applications (Current Revision)
FAA-G-2100	Electronic Equipment, General Requirements (Current Revision)

FAA 6560.13 Maintenance of Aviation Meteorological Systems And
Miscellaneous Aids (Current Revision)

NAS-IC-25083101A ADAS/AWSS-ASOS-AWOS ICD (Current Revision)

50-SANW-1-00050 NWS ASOS Algorithm (Current Revision)

3. FUNCTIONAL REQUIREMENTS

3.1 Introduction

This section presents the AWSS system requirements. Included are the system characteristics in Section 3.2 that includes a system description of major sub-assemblies. Section 3.3 provides the detailed requirements for each sensor component. Section 3.4 provides the operational environment requirements for the AWSS. Section 3.5 provides the reliability, maintainability and availability requirements for the system. Detailed hardware requirements are as identified in Sections 3.6 through 3.11.

3.2 System Characteristics

3.2.1 System Description

The AWSS is a modular system, designed to automatically collect, process, disseminate, and archive weather sensor measurement data. Access to this data is available to a variety of users at local and remote locations on a 24-hour basis. The AWSS configuration consists of various components as shown on Figure 3.2.1-1. The weather data is collected by the sensors and sent through the Field Data Collection Unit (FDCU) to the Terminal Data Acquisition Unit (TDAU). The TDAU software processes the weather data, generates reports, archives data, and establishes the communications required to transfer data to external devices. Concurrent with these operations, the continuous self-test program monitors the operational readiness of the system. The individual weather parameter data monitored and processed consists of:

1. Sky Condition
2. Cloud Height
3. Visibility
4. Present Weather type and intensity
5. Obscurations
6. Pressure (altimeter, station, density altitude, pressure altitude and sea level)
7. Temperature, relative humidity, and dewpoint
8. Wind (speed, direction, gust character, and variability)
9. Precipitation amount
10. Freezing rain (Optional)

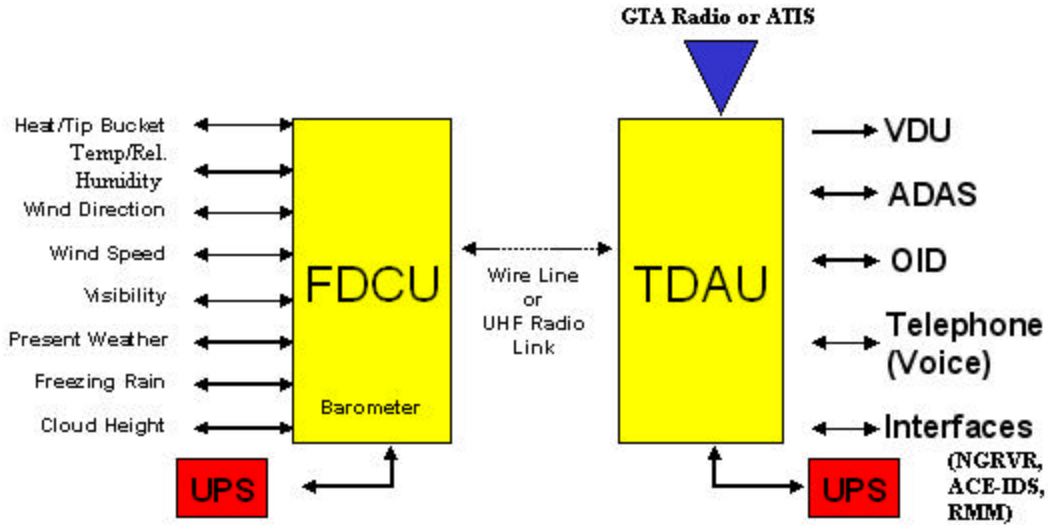

Figure 3.2.1-1 AWSS Block Diagram

3.2.2 Sensors

The AWSS sensors must provide signal output representing the sensed weather element data to the FDCU. Section 3.3 contains the detailed performance requirements for the sensors. The following are general requirements that apply to all sensors:

1. Environmental sensors: The sensor group(s) must measure the required meteorological variables.
2. Signal outputs: These sensors must provide signal outputs representing the sensed weather element data to the FDCU.
3. Interchangeability: The AWSS Sensors must be interchangeable between individual sites.
4. Calibration constants: The AWSS Sensors must not require individual site adjustments except for calibration constants. Calibration constants may be entered into the overall system configuration when a sensor is installed.
5. Coding: The AWSS Sensor data must be encoded into digital form.
6. Built-in test: Digital sensors must have built-in-tests (BIT) that are routinely exercised automatically.
7. Missing sensor: Whenever a digital sensor test fails, the sensor must be reported missing.
8. Sensor output: Sensor output must conform to a fixed transfer function.

9. Outdoor environment: Sensors (except pressure) must withstand the outdoor environment requirements as specified in Section 3.4.

3.3 PERFORMANCE REQUIREMENTS

The sensor performance requirements apply not to the sensor alone, but to the sensor as it is used in the system, e.g., any degradation in the measured parameter because of system processing must be accounted for in meeting the reliability, maintainability, and availability (RMA) requirements specified in Section 3.5.

3.3.1 Wind Speed and Direction Sensors

1. Speed range: The sensor should respond to a threshold of 2 knots and a maximum of at least 85 knots.
2. Resolution: The resolution must be one (1) knot.
3. Wind speed accuracy: The wind-speed sensor must provide an accuracy of ± 2 knots up to 40 knots. Above 40 knots, RMSE must be within ± 5 percent.
4. Speed distance constant: The distance constant for wind speed must be no more than 30 feet.
5. Direction accuracy: The wind direction accuracy must be within 5 degrees RMSE, with a maximum error of 10 degrees on any direction.
6. Resolution: The resolution must be 1 degree (0 to 359 degrees excluding the “dead band”) with an allowable “dead band” of up to 10 degrees.
7. Alignment: The wind direction sensor must be aligned to true north.
8. Alignment restoration: Upon restoration of the sensor to its mounting position, the sensor must be accurately restored to the prior directional alignment without the necessity for another alignment survey.
9. Operational conditions: The wind speed and direction sensors must operate during conditions of 0.25-inch radial thickness of clear ice and wind speeds higher than 10 knots.
10. Sample rate: The sensors must be sampled at a rate sufficient to provide five-second averages.

3.3.2 Temperature and Relative Humidity Sensor

1. Temperature range: The temperature sensor must measure temperature from – 65 °F to +130 °F.
2. Temperature sensor accuracy: The temperature sensor accuracy must be 1 degree RMSE with a maximum error of 2 degrees F.
3. Temperature sensor resolution: The resolution of the temperature sensor must be not greater than 1 °F.
4. Relative Humidity sensor range: The relative humidity sensor must measure all dew point temperatures, in one-degree increments, between –30 °F to +90 °F.
5. Relative Humidity sensor resolution: The resolution of the relative humidity sensor must not be greater than 1 %.
6. Relative Humidity sensor accuracy:
 - a. The accuracy (RSME) of the relative humidity sensor must be 2 °F dew point for dry bulb temperatures of +30 °F to +90 °F (80 to 100% relative humidity), with a maximum error of 3 °F at any dry bulb temperature.
 - b. The accuracy (RSME) of the relative humidity sensor must be 3 °F dew point for dry bulb temperatures of +30 °F to +120 °F (15 to 75% relative humidity), with a maximum error of 4 °F at any dry bulb temperature.
 - c. The accuracy (RSME) of the relative humidity sensor must be 4 °F dew point for dry bulb temperatures of -20 °F to +20 °F (25 to 90% relative humidity), with a maximum error of 5 °F at any dry bulb temperature. The minimum dew point required is –30 °F.

3.3.3 Pressure Sensor

1. Redundancy: Three sensors are required per system.
2. Elevation: The pressure sensors must measure the station barometric pressure at any elevation between 0 and 12,200 feet above mean sea level. Each sensor must meet the following:
3. Range: The pressure sensor must measure barometric pressure between 17.5 in. Hg and 31.5 in. Hg.

4. Accuracy: The accuracy must be ± 0.02 inch of mercury over a 4.5-inch measurement range at any altitude from 0 to 12,200 feet.
5. Resolution: The resolution of the barometer must be 0.003 inch of mercury.
6. Venting: The contractor must provide outside venting as required by the current revision of FAA Order 6560.
7. Interrogation rate: The pressure sensor must be interrogated once every 10 seconds.
8. Differential accuracy: Each sensor must exhibit a differential accuracy of 0.01 inch of mercury or less between any two pressure measurements taken from the same sensor 3 hours apart. (Ambient temperature over this 3-hour period must not vary more than 5 °F; ambient pressure must not vary more than 0.1 in. Hg over the 3-hour period.)

3.3.4 Visibility Sensor

1. Extinction coefficient: The visibility sensor must provide an extinction coefficient equivalent to up to at least 10 miles.
2. Mount: It must be a single-pedestal mount capable of operation with a line of sight restricted to 500 feet.
3. Reportable increments: The reportable increments of visibility must be (in statute miles): $<1/4$, $1/4$, $1/2$, $3/4$, 1, $1\ 1/4$, $1\ 1/2$, $1\ 3/4$, 2, $2\ 1/2$, 3, 4, 5, 7, and 10.

Table 3.3.4-1 Sensor Accuracy Table (% of all data)

NWS Standard Transmissometers			at least 80% within	at least 98% within	100% within these limits
0	through	1 1/4	$\pm 1/4$	$\pm 1/2$	± 1
1 1/2	through	1 3/4	$+1/4, -1/2$	$+1/2, -3/4$	± 1
2	through	2 1/2	$\pm 1/2$	± 1	± 1
3	through	4	± 1	$+2\ RI^*, -1$	$+2\ RI^*, -1$
4	through	10+	$\pm 1\ RI^*$	$\pm 2RI^*$	$\pm 2\ RI$

***RI = Reportable Increment, all other values in miles (Note: no 3 1/2 or 4 1/2 mi bin)**

4. Editing: The AWSS software must allow editing to include visibility increments less than 1/4 mile and greater than 10 miles.
5. 0 – 1-mile visibility: For visibility between 0 and 1 mile the visibility sensors must meet the requirements of the Sensor Accuracy Table 3.3.4-1

6. 1 ¼ – 10+ miles visibility: For visibility between 1 ¼ to 10+ miles the visibility sensors must meet the requirements of the Sensor Accuracy Table 3.3.4-1
7. Visual light transmissometers: The visual light transmissometers must have an absolute calibration and uniform transmit beam that is not affected by tower motions. (Note: in using the table, when positive tolerance results in a non-reportable bin, round to the next higher reportable increment.)
8. Photometer: A photometer must be provided to indicate whether the ambient light level is day or night.
9. Day/night indication: The photometer must always indicate day for illumination > 3 foot-candles (FC) and night for illumination < 0.5 FC.
10. Transition from night to day: Transition from indicating night to indicating day must occur once in the region between 0.5 and 3.0 FC (as the illumination increases).
11. Transition from day to night: Transition from indicating day to indicating night must occur once in the region from 3 to 0.5 FC (as the illumination decreases).
12. Diagnostics: The photometer must have associated diagnostics so that Remote Maintenance Monitoring (RMM) can verify that it is operational.
13. Photometer orientation: The photometer must be mounted facing the north sky and must operate with ambient levels up to 50 FC.
14. Snow effect: The sensor must be such that snow buildup must not interfere with its operation.
15. Calibration: The visibility sensor must be provided a means for field calibration.

3.3.5 Ceilometer

1. Range: The cloud height sensor must accurately operate, by measuring cloud heights and the heights of obscuring phenomena aloft, from its installed location to a minimum height of 12,500 feet.
2. Output: The sensor must provide an output of at least two cloud layers representative of the sky conditions when surface visibility is equal to or greater than ¼ mile.

3. Accuracy: The cloud height sensor must provide an accuracy of 100 feet or 5 %, whichever is greater.
4. Resolution: The resolution of the ceilometer must be no more than 50 feet.
5. Eye safety: The Ceilometer sensor must conform to ANSI-Z-1136.1, Accessible Emission Limits for Laser Radiation, with Class 3B maximum accessible emission level applied to direct viewing without optical instruments (excluding ordinary eyeglasses).

3.3.6 Liquid Precipitation Accumulation Sensor

1. Range: The liquid precipitation accumulation sensor must measure the amount of precipitation accumulation between 0.0 to 10.0 inches per hour.
2. Resolution: The liquid precipitation accumulation sensor resolution must be 0.01 inch.
3. Accuracy: The liquid precipitation accumulation sensor accuracy must be \pm 0.02-inch or 4% of the hourly total (whichever is greater).
4. Interrogation rate: The tipping bucket must produce an output to the FDCU whenever 0.01 inches of precipitation is detected.

3.3.7 Freezing Rain Occurrence Sensor

1. Correctness: The freezing rain occurrence (ZR) sensor must detect freezing rain correctly 99% of the time whenever freezing rain has accumulated to 0.01 inch.
2. False alarm rate: The sensor false alarm rate must not exceed 0.01% when there is no precipitation, or when there is rain at temperatures above 40 °F.
3. Interrogation rate: The sensor must be interrogated at least once per minute to provide reports of onset and cessation.

3.3.8 Precipitation Identification Sensor

1. Detection threshold: The precipitation identification sensor must detect rainfall and wet snow at a rate of 0.01 inch per hour, as measured using a Heated Tipping Bucket Gauge.
2. Correctness: The liquid precipitation must be correctly detected at least 99% of the time (reported as either “RA” or “UP”) and must be correctly identified at least 90% of the time.

3. False alarm rate: The false alarm rate must be less than or equal to 0.2%.
4. Weather situation identified: The sensor must provide measured data to the present weather algorithm so that the following weather situations must be identified:

“-“	Light
“+”	Heavy
“No sign”	Moderate

Light Rain
 Moderate Rain
 Heavy Rain
 Light Snow
 Moderate Snow
 Heavy Snow
 Mixed or other Precipitation

5. Precipitation start/end reporting duration: The sensor must report the start and end of a precipitation event within five minutes of the time that it occurs.
6. Interrogation rate: The sensor must be interrogated at least once per minute.

3.3.9 Lightning and Thunderstorm Reporting

1. ALDARS: Lightning information at select locations must be provided to the AWSS from the FAA Automated Lightning Detection And Reporting System (ALDARS) in accordance with the current revision of the ADAS/AWSS-ASOS-AWOS Interface Control Document NAS-IC-25083101.
2. Processing: The TDAU must process the lightning data in accordance with the ASOS algorithms and the current revision of the ADAS/AWSS-ASOS-AWOS Interface Control Document NAS-IC-25083101.

3.4 Environmental Limits

3.4.1 Site Elevation

The AWSS must operate from at least 100 feet below sea level to at least 10,000 feet above sea level.

3.4.2 Equipment Installed Indoors in a Conditioned Space

1. Temperature: All indoors-installed AWSS equipment must operate from at least 40 °F to +105 °F.

2. Relative humidity: All indoors-installed AWSS equipment must operate from at least 5% to 90% (non-condensing).

3.4.3 Equipment Installed Outdoors

1. Temperature: All outdoors-installed AWSS equipment must operate from at least -65°F to $+130^{\circ}\text{F}$.
2. Relative humidity: All outdoors-installed AWSS equipment must operate from at least 5% to 100%.
3. Wind: All outdoors-installed AWSS equipment must operate with wind up to 85 knots.
4. Ice buildup: All outdoors-installed AWSS equipment must operate in freezing rain rates equivalent to a buildup of 0.5 inch per hour. The accuracy of the wind sensors is permitted to deteriorate during icing conditions.
5. Rain: All outdoors-installed AWSS equipment must operate in rain up to 3 inches per hour with 40-knot wind.

3.4.4 Electromagnetic Interference

Electromagnetic Interference (EMI) requirements are for indoor equipment only. (Note: EMI requirements are applicable for Tower OID and TDAU cabinet equipment.) Emissions and susceptibility to electromagnetic interference must be controlled such that the equipment complies with the following provisions of MIL-STD-461E:

1. CE101 conducted emission, power and interconnecting leads, low frequency (up to 15 KHz).
2. CE102 conducted emission, power and interconnecting leads, low frequency (0.015 to 50 MHz).
3. CS101 conducted susceptibility; power leads (30 Hz to 50 Hz).
4. CS114 conducted susceptibility; power and interconnecting control leads (0.05 to 400 MHz).
5. CS115 conductive susceptibility, spikes, power leads.
6. RE101 radiated emission, magnetic field (0.03 to 50 kHz).
7. RS101 radiated susceptibility, magnetic field (0.03 to 50 kHz).
8. RS103 radiated susceptibility, electric field, 14 kHz to 3 GHz at 10 volts/meter.

3.5 Reliability, Maintainability, and Availability Requirements

3.5.1 Mean Time to Repair (MTTR)

The system must have a MTTR of no more than 30 minutes, at a 95% confidence level.

3.5.2 Preventive Maintenance

Preventive maintenance visits must not be required more than once per 90 days.

3.5.3 Operational Availability Requirements

The AWSS A_O requirements for both correct and error-free operation are specified in Table 3.5.3-1. Two required aspects of availability are listed in the table. The first category, “correct” A_O , requires that correct information be provided for that parameter as a system output. Since missing information is more acceptable than erroneous information, the second category is the availability of a parameter that is not incorrect; i.e., the output will be either reported correctly or be missing. In Table 3.5.3-1 this availability is labeled “error-free”. For phenomena that are not continuous, e.g., freezing precipitation occurrence, the specified availability applies to those periods in which the phenomena occur. For each type of A_O , the value is intended to represent the percent of total time that a parameter is measured, processed, and displayed on an output device in an acceptable form. The calculation for A_O that will be used to evaluate compliance with these requirements is expressed by:

$$A_O = \text{MTBF} / (\text{MTBF} + \text{MOT})$$

Where:

MTBF = Mean Time Between Failure of the system to report an acceptable form (i.e., correct or error-free)

MOT = Mean Outage Time, to include Mean Time To Repair (MTTR), Mean Supply Response Time (MSRT), Mean Maintenance Delay Time (MMDT), and Mean Other Logistics Delay Time (MOLDT)

MOT = MTTR + MSRT + MMDT + MOLDT

MTTR = Mean Time To Repair including fault isolation, remove and replace, checkout, And systems restart time

MSRT = Mean Supply Response Time waiting for arrival of required spare parts at a site

MMDT = Mean Maintenance Delay Time waiting for the arrival of maintenance personnel at a site

- 3. Visibility: A visibility of less than 4 miles is not correctly reported.
- 4. Wind: Wind speed, direction, or gust is not correctly reported and the average wind is at least 4 knots.
- 5. Freezing Rain: The occurrence of 0.01 inch of freezing rain is not correctly reported.
- 6. Precipitation: Precipitation is of moderate or heavy intensity, and the occurrence, amount, type or intensity of precipitation is not correctly reported.
- 7. Temperature/Dew point: Temperature or dew point is not correctly reported.

3.5.5 Data Quality Requirements

3.5.5.1 Algorithms data quality checks

AWSS algorithms must contain data quality checks to ensure accurate reporting of weather information. No sensor-specific algorithms must be used in generating the required system output.

3.5.5.2 Trends monitoring requirement

Weather sensor trends must be continuously monitored and analyzed to determine deterioration of sensor performance and provide information to the appropriate person(s) if a sensor requires maintenance actions. The trend for deterioration of sensor performance must be such that any one or more individual sensor parameters that is exceeding the rate of decreasing accuracy or resolution, over time, than the individual sensor’s specification requirements.

3.5.5.3 Data quality degradation reporting requirement

Data quality must be monitored to ensure proper operation of sensors, software, firmware, hardware, and the AWSS. Data quality degradation trends that demonstrate incorrect operation within 24 hours must be identified by the AWSS; and the AWSS must alert the operator, via the OID, of a sensor malfunction and note the problem in the maintenance log.

3.5.5.4 Failed data

The operator alert and the maintenance log must identify the specific data check that failed.

3.5.6 System Diagnostic Capability

Since the AWSS will be providing critical weather information to support aviation operations; it is essential that the system be able to self-detect performance degradation to avoid reporting incorrect data. To support this mission, the AWSS must have the following diagnostic capability: continuous self-testing and diagnosis that runs automatically and maintenance testing.

3.5.6.1 *Continuous Self-Test requirement*

The AWSS must check all electronic Line Replaceable Unit (LRU) functions for the FDCU, TDAU, sensors, buses, and communications.

1. Equipment status and performance analysis requirement: Equipment status and performance must be automatically and continuously analyzed to determine trends signifying degraded operation.
2. Display of error messages requirement: Error messages must be displayed on the Operator Interface Device (OID) and include interpretation and advice in English, detailing specifics on failures, actions required, identification of marginal or degraded system operation, and identification of specific LRUs that need to be replaced.
3. Detection out-of tolerance requirement: The AWSS must detect out-of-tolerance conditions or failures to the LRU level.
4. Self-Test monitoring requirement: The AWSS must allow a technician to monitor the results of the continuous self-test from both the TDAU and via remote dial-in. To isolate the failure to an LRU, the maintenance technician must use this level of diagnostic capability, such as modem loop back, if required.
5. Signal loss detection requirement: The AWSS must detect and display on the OID accordingly the loss of any signal.
6. Failed LRU detection requirement: The AWSS must detect and display on the OID accordingly the removal or failure of any critical (LRU) that would result in a system critical error, or system failure.
7. Sensor failure indication requirement: The AWSS must detect any indication of sensor failure or degradation.

3.6 Field Data Collection Unit (FDCU)

The AWSS requirements must incorporate separate subsystems for collecting sensor data (Field Data Collection Unit (FDCU)) and data processing (Terminal Data Acquisition Unit (TDAU)).

3.6.1 Data Sources

3.6.1.1 Wind speed

The FDCU must acquire data from the Wind Speed sensor.

3.6.1.2 Wind direction

The FDCU must acquire data from the Wind Direction sensor.

3.6.1.3 Temperature & Relative Humidity

The FDCU must acquire data from the Temperature and Relative Humidity sensor.

3.6.1.4 Liquid precipitation

The FDCU must acquire data from the Liquid precipitation accumulation sensor.

3.6.1.5 Freezing rain (Optional)

The FDCU must acquire data from the Freezing rain occurrence sensor.

3.6.1.6 Precipitation Identification

The FDCU must acquire data from the Precipitation identification sensor.

3.6.1.7 Ceilometer

The FDCU must acquire data from the Ceilometer sensor.

3.6.1.8 Visibility, day/night

The FDCU must acquire data from the Visibility (including day/night sensor) sensor.

3.6.1.9 Barometric pressure

The FDCU must acquire data from the Barometric sensors

3.6.1.10 *Supply voltage*

If a sensor reports a supply voltage, then the FDCU must acquire supply voltage status signals from the sensors.

3.6.1.11 *Status signals acquisition requirement from the sensors*

If a sensor reports a status signals, then the FDCU must acquire current status signals from the sensors.

3.6.1.12 *Status signals acquisition equipment for heater*

If a sensor reports a heater status signals, then the FDCU must acquire heater status signals from the sensors.

3.6.1.13 *Built-In Test*

The FDCU must perform a self-test.

3.6.1.14 *Expansion capability of sensors*

The FDCU must accommodate up to 16 inputs.

3.6.2 FDCU Timing and Control

3.6.2.1 *FDCU Timing and control*

Timing and control functions must include sequencing and control of data acquisition, signal conditioning, scaling and conversion, storage, data formatting, commands and data transfer, and test modes.

3.6.2.2 *FDCU data transmissions interference requirement*

Data transmissions between the FDCU and TDAU must not interfere with normal FDCU functional operation.

3.6.2.3 *Watchdog Timer*

A watchdog timer must be provided to produce a system reset/re-boot in the event of hardware malfunction or unrecoverable software error.

3.6.3 FDCU Data Acquisition and Signal Conditioning

Means must be provided to acquire the instantaneous values of the sensor signals. Preconditioned signals (analog, digital, or other) must be converted to digital words. The

English system of measure must be used unless otherwise specified. Testing of sensors must not adversely affect the operation of sensors not involved in the test.

3.6.4 FDCU Data Communications

3.6.4.1 FDCU to TDAU communications requirement

Data communications between the FDCU and the TDAU must be via serial digital transfer.

3.6.4.2 Radio link frequency operate band and output power requirement

If a serial digital transfer link is a radio the radio must be an Ultra High Frequency (UHF) type with adjustable transmitter output power not to exceed 1 watt.

3.6.4.3 Antenna and cable type requirements

Both the FDCU and the TDAU must use a directional antenna. UHF transmission must be a Yagi directional antenna such as Kathertin-Scala CA-7 or equivalent must be used. All antenna cablings must be RG-214.

3.6.4.4 EMI/RFI

The installed system must conform to the EMI/RFI requirements of section 3.4.4.

3.6.5 RF Equipment Location

The RF link equipment, if desired, must be co-located with but separate from the FDCU and must meet the special packaging and housing requirements.

3.6.6 FDCU Power Control and Distribution

3.6.6.1 Uninterruptible Power Supply

The FDCU must be provided with an Uninterruptible Power Supply (UPS) system as described in Section 3.11.

3.6.6.2 Degradation / loss of performance requirement

Loss of primary power to the FDCU and all associated sensors and peripherals must not result in degradation or loss of performance for at least 20 minutes.

3.6.6.3 *Nonvolatile memory saving requirement*

After a 20-minute loss of primary power or when the backup battery can no longer provide the minimum backup power, the FDCU must perform an orderly shutdown without loss of captured data.

3.6.6.4 *System restart requirement*

After a shutdown has occurred and power is restored, the FDCU must automatically restart all data files and re-boot, if necessary.

3.6.6.5 *Power outage record requirement*

For the FDCU, upon restoration of normal power after a shutdown, a record of the power outage must be archived in the maintenance log and the system must automatically restart all functions.

3.7 Terminal Data Acquisition Unit (TDAU)

3.7.1 Functional requirements

The TDAU must acquire, process, format, store and report data.

3.7.2 OID requirements

The unit must accept, at a minimum, a total of three OIDs.

3.7.3 Timing requirements

The TDAU must contain the hardware and firmware/software necessary to perform the following functions:

1. system timing and control
2. data acquisition
3. system communications
4. data processing, formatting, and storage
5. data quality checks
6. archiving
7. power control and distribution
8. system diagnostics
9. data output

3.7.4 TDAU Timing and Control Functions

3.7.4.1 Time out & restart

The TDAU must control and schedule time outs and restarts when processes are interrupted or nonfunctional.

3.7.4.2 Entry & display

The TDAU must control and schedule manual entries and display functions.

3.7.4.3 Data collection

The TDAU must control and schedule synchronous data collection.

3.7.4.4 One-Minute Data

The TDAU must control and schedule synchronous input of the One-Minute Data observations.

3.7.4.5 Reports

The TDAU must control and schedule METAR, and SPECI reports.

3.7.4.6 Watchdog Timer Function

The TDAU must have a watchdog timer function to provide a system reset in the event of software malfunction.

3.7.5 System Clock

The AWSS must use a System Clock as a time reference for all events within the TDAU.

3.7.5.1 Source

The System Clock must be contained within and a product of the processor.

3.7.5.2 Use

The time must be in units of days, hours, and seconds and is provided as a system output for use in system displays, computer –generated voice output, etc.

3.7.5.3 Date Format

The day must be expressed in the Gregorian calendar format.

3.7.5.4 Time Format

Hours and minutes must be indicated numerically from 0000 to 2359.

3.7.5.5 Accuracy

The clock must be accurate within 15 seconds each month.

3.7.5.6 Control

The operator must be able to set or reset the System Clock, from any OID interfaced to the AWSS.

3.7.5.7 Backup power

The System Clock must contain a rechargeable long-term power supply (minimum 2 years) or non-rechargeable 5-year backup power supply to maintain the clock at specified accuracy during AC power outages.

3.7.5.8 Timing

Synchronized timing must be provided for all data acquisition, communication and processing functions to ensure proper execution of all system functions.

3.7.5.9 Control functions

Control functions must include data acquisition, operating peripherals, and reporting data via communication ports.

3.7.6 TDAU Data Acquisition and Communications

3.7.6.1 Video Display Unit

The TDAU must communicate with up to four video display units (VDUs).

3.7.6.2 Communication circuits

Additional interfaces must be provided to communicate with various communication circuits.

3.7.6.3 Voice communication

Additional interfaces must be provided to communicate with voice outputs.

3.7.6.4 *Telephone communications*

Additional interfaces must be provided to communicate with telephone interfaces.

3.7.7 **Data Processing**

3.7.7.1 *Engineering units*

The TDAU must convert sensor data into engineering units (if not performed by the FDCU).

3.7.7.2 *Averaging*

The TDAU must average the measurements as appropriate for each measured value.

3.7.7.3 *One-Minute Data*

The TDAU must calculate the One-Minute Data for display, voice, and long line transmission.

3.7.7.4 *METAR/SPECI messages*

The TDAU must prepare hourly METAR/SPECI messages at the hourly report time $h - 5$.

3.7.7.5 *Transmission interval*

The METAR/SPECI messages must be transmitted at the hourly transmission time. The METAR report must be adjustable in 1 minute increments over a ± 5 minutes period around $h - 5$.

3.7.7.6 *Notification requirement for METAR or SPECI observation prepared*

The TDAU must provide notification via alarms to operators whenever a METAR or SPECI observation is prepared.

3.7.7.7 *Notification requirement for METAR or SPECI observation pending*

The TDAU must provide notification of the form "HOURLY PENDING" or "SPECI PENDING" on the top of one-minute screen while a METAR or SPECI observation is pending.

3.7.7.8 *Monitor data thresholds and processing requirement for SPECI*

The TDAU must continuously monitor data thresholds to determine if special reports are required. The TDAU must prepare a SPECI using METAR format.

3.7.7.9 *Processing requirement of Special Observation*

TDAU Processing must continue during the period between detection and transmission of the Special Observation. If the processing indicates a need for another SPECI then:

1. If the second special is caused by reversal of the ceiling or visibility trend, which caused the initial special, neither must be transmitted. A message must be sent to the OID screen(s) indicating that the SPECI was canceled.
2. If the second special is caused by continuation of the ceiling or visibility trend, which caused the initial special; or if the second special is caused by a different parameter than the initial special, the first special must be deleted and not transmitted. The second special must be transmitted immediately.
3. If the METAR report time occurs while a special is pending, the special must be deleted and the METAR observation must be transmitted at the hourly transmission time.
4. If a METAR observation is pending when a special continuation occurs, delete the specials and transmit the METAR at hourly transmission time.
5. If a METAR observation is pending when a SPECI reversal occurs, cancel the SPECIs, and transmit the METAR at the hourly transmission time.

3.7.7.10 *Quality check*

The TDAU must perform quality check of the parameters. This must include sensor out-of-limits checks plus time continuity and comparison checks. When errors are detected, the system must discontinue reporting of affected parameters.

3.7.7.11 *Notification*

The TDAU must provide notification via alarms to the OID and set the ADAS alert bit.

3.7.7.12 *Fault ID*

The TDAU must provide identification of the fault by appending a status character to the METAR, and store the fault identification as maintenance data.

3.7.7.13 *System restart*

If sensor quality is restored, the system must restart parameter reporting and note restoration/repair in the maintenance log. However, pressure reporting must never be restarted automatically after an error has been detected.

3.7.7.14 Monitor operator interface requirement

The TDAU must continuously monitor operator interface functions to incorporate operator changes that affect the algorithm processing and data output.

3.7.8 Data Formatting and Archival

3.7.8.1 Data formatting and archival criteria

The AWSS system must retain a record of the One-Minute Data and METAR/SPECI reports, as well as the data entered through the keyboard, for use by accident investigators.

3.7.8.2 Archive interval

The interval between archived reports must not be more than 20 minutes.

3.7.8.3 Report retention

The archived report must be retained for at least 96 hours (4 days) (i.e., 96 hours of data is archived on a first in, first out sequence).

3.7.8.4 Archive retrieval medium requirement

A method must be provided for the retrieval of archived reports using a computer disk, and the operator must be able to suspend, locally or remotely, the updates of the archived weather reports to freeze the data until retrieval may be accomplished.

3.7.8.5 Maintenance data archived duration requirement

The TDAU must archive maintenance data for 31 days plus so far today.

3.7.9 Data Quality

3.7.9.1 Sensor self-test status signals and data quality checks requirements

Sensor self-test status signals and data quality checks must be processed by the TDAU to ensure the section 3.5 RMA requirements.

3.7.9.2 Missing parameter requirements

Whenever this processing indicates that a parameter is to be reported missing, the system must activate audible and visual alarms and replace the appropriate parameters with “M”.

3.7.9.3 Alarms requirement for report processing

Alarms must not be activated if a parameter is reporting missing due to report processing being turned off by the operator.

3.7.9.4 Sensor data accessibility requirement

Sensor data must remain accessible to an operator via the OID.

3.7.9.5 Status character requirement

The status character must be appended to all METAR until a technician has taken corrective action.

3.7.9.6 Error detection/correction requirements

AWSS must employ error detection and correction on all information transmitted on communication circuits.

3.7.10 TDAU Power Control and Distribution

3.7.10.1 Uninterruptible Power Supply

The TDAU must be provided with an Uninterruptible Power Supply (UPS) system described in Section 3.11.

3.7.10.2 Degradation / loss of performance requirement

Loss of primary power to the TDAU and all associated sensors and peripherals must not result in degradation or loss of performance for at least 20 minutes.

3.7.10.3 Nonvolatile memory saving requirement

After a 20-minute loss of primary power or when the backup battery can no longer provide the minimum backup power, the TDAU perform an orderly shutdown without loss of captured data.

3.7.10.4 System restart requirement

After a shutdown has occurred and power is restored, the TDAU must automatically restart all data files and re-boot, if necessary.

3.7.10.5 *Power outage record requirement*

For the TDAU, upon restoration of normal power after a shutdown, a record of the power outage must be archived in the maintenance log and the system must automatically restart all functions.

3.7.11 **TDAU/Peripheral interface requirements**

The TDAU must provide interfaces to peripheral equipment including: Video Display Units (VDUs), Operator Interface Devices (OIDs), and a Ground to Air (GTA) transmitter.

3.8 **Operator Interfaces**

3.8.1 **OID Requirements**

3.8.1.1 *OID general requirements*

The OID must consist of a video display and a keyboard, which are connected to the TDAU via a keyboard video mouse (KVM) extender.

3.8.1.2 *Primary OID/TDAU distance requirement*

The primary OID must be located up to 600 feet from the TDAU.

3.8.1.3 *Local OID*

The system must provide a means to connect a Local OID. The Local OID must be a VT-220 type terminal, using an asynchronous serial connection..

3.8.1.4 *Secondary OID transmission distance/rate*

If required, the contractor must offer the capability to extend the distance of a secondary OID to 8 miles, using a short haul modem capable of a transmission rate of 9600-baud or higher.

3.8.1.5 *OID display capability requirements*

The OID display must be readable by a person with normal vision (corrected to 20/20) in levels varying from normal office lighting to near darkness, at angles up to 45 degrees to the plane of the display, and at a distance of 6 feet.

3.8.1.6 *OID screen and size requirements*

The screen must be non-glare, rectangular and a minimum of 12 inches diagonal.

3.8.1.7 OID audible alarm requirement

The device must include a variable intensity audible alarm.

3.8.1.8 OID display resolution, characters and line requirements

The OID must be capable of displaying 80 characters per line on a minimum of 25 lines.

3.8.1.9 OID update rate requirement

The display must be flicker-free with an update rate of at least 60 Hz.

3.8.1.10 OID colors display requirement

The display must be at least (8) eight colors.

3.8.1.11 OID Character box requirement

Character box must be at least 8 pixels wide by 8 pixels high.

3.8.1.12 OID display control function requirements

The OID display control must consist of at least:

1. ON/OFF switch
2. Contrast control
3. Brightness control
4. Audible alarm intensity

3.8.1.13 OID display format requirement

The display must accept data from the TDAU and display that data in the OID formats specified in the AWSS Software Users Manual (SUM) for operator interaction through the keyboard.

3.8.1.14 OID display highlighting capability

The OID display must have a highlighting capability (e.g., varying colors, varying levels of brightness or reverse video).

3.8.1.15 OID Function keys/cursor requirement

The OID keyboard must provide active function keys, and separate active cursor control keys for performing the OID functions described in the SUM.

3.8.1.16 OID keyboard layout requirement

Keys must have a layout similar to a standard PC keyboard and must have tactile feedback.

3.8.1.17 OID/TDAU port data rate requirement

When the TDAU OID port is active, and it is the only active OID port, the OID must operate at a speed of at least 9600 bps.

3.8.1.18 Operator/OID interact requirements

The operator must be able to interact with the AWSS, performing various functions through the OID. The functional requirements are defined by the AWSS SUM. All operator functions must be accessible through all on-site OIDs. All remote operator functions must be available via telephone ports.

3.8.1.19 Remote function security requirement

The remote function must not be available until after the operator provides an access code. AWSS must disconnect communications with an unsigned remote user after 5 minutes has elapsed from the completion of the last transmission to that remote user.

3.8.1.20 OID password requirement

Passwords must be provided for each type of operator.

3.8.1.21 Simultaneous execution of OID commands requirements

Simultaneous execution of OID commands requirements from more than one terminal is not required; however, response to and servicing of more than one terminal simultaneously is required.

3.8.1.22 OID audible and visual alarm requirements

The OID must notify operators by audible alarm of variable intensity and visual alarm under control of the TDAU in accordance with the AWSS SUM.

3.8.1.23 Audible alarm duration requirement

The audible alarm must not last more than one minute and must be easily disabled by the operator both against future alarms, and when it sounds. A message must be displayed (on the one-minute screen) which indicates the status of the alarms.

3.8.1.24 *OID keypad labels requirements*

Keypad labels, as described in the AWSS SUM, must always be displayed on the OID screen.

3.8.1.25 *Observation display for METAR or SPECI availability for edit requirements*

When a METAR or SPECI is available for edit, (i.e., pending) the pending observation must be displayed on the one-minute screen in place of the transmitted observation. If an operator enters a command and no keystrokes are performed within 2 minutes ± 15 seconds, the system must automatically exit the command mode and revert to the one-minute screen.

3.8.2 **OID signed on functional requirements**

The following functions must be available to all signed on operators (Air Traffic Controller (ATC) has limited capability as defined under ATC functions):

3.8.2.1 *Sign ON/OFF requirement*

Only one observer must be signed on the system at any given time. Only one controller must be signed on at given time.

3.8.2.2 *Controller review files list*

Controller files assessing for review listed below:

1. Observations (METAR)
2. One-Minute Data
3. Current sensor data
4. Site-specific data (except external communications data, available only to technicians and system managers)
5. Maintenance Log
6. Communications Log
7. Five-minute observations for the past 96 hours
8. Archived observations for selected 2 hour period during the past 4 days

3.8.2.3 *AUX function key requirement*

AUX function key must invoke a menu of the following functions:

1. WEATHER (i.e. AUX data)
2. USERS
3. SENSORS IN MANUAL
4. OFF
5. EXIT

3.8.2.4 *OID manual data update timing requirement*

The data provided for WEATHER, USERS, and SENSORS IN MANUAL must be updated each minute.

3.8.2.5 *Report processing requirements*

If report processing is turned off and left in automatic mode then:

1. The output to the general display and observations for that sensor must be “M” for missing.
2. The “M” must be highlighted on the next update of the one-minute screen.
3. The audible alarm must sound for 1 minute.
4. The sensor data must remain accessible for review via the OID function.
5. The status character must be appended to all METAR surface aviation observations until corrective action has been taken.
6. The sensor data in the 12-hr archive must be flagged on the screen.
7. Except for the ZR, LEDWI, and thunderstorm sensors, all automated remarks generated by the sensor must be automatically deleted.

3.8.2.6 *Report processing requirement for precipitation sensor*

Whenever Report Processing is turned off for the precipitation sensor or if the precipitation sensor is reconfigured, the system must examine the user status to see if an OBS is signed on.

If an OBS is not signed on:

1. The system must delete the automated present weather remark and generate the remark PWINO until report processing is turned back on or the sensor is reconfigured or enabled.
2. The remark ZRNO must also be appended if the five-minute ambient temperature is less than or equal to 36 degrees F or is missing.
3. The remark ZRNO must not be appended if the five-minute ambient temperature is greater than 36 degrees F.

If an OBS is signed on:

1. The remark PWINO must not be generated. The words “PRECIP IDENT DATA N/A” must be flashed in a high contrast color for a period of one minute on the bottom of the one-minute screen. The message “PRECIP IDENT DATA N/A” must continue to be displayed until report processing is turned back on or the sensor is configured or enabled.
2. When the precipitation identifier sensor is configured, enabled, and contains no data quality errors, the system must remove PWINO from the remarks.
3. If the ZR sensor is configured, enabled, and has no data quality errors, the system must remove the ZRNO remarks.
4. Whenever the precipitation identifier data is restored, and the OBS is logged on, the system must announce the restoration of the present weather identifier data by flashing the words: “PRECIP IDENT DATA AVAILABLE”, at the bottom of the one-minute screen for a period of 1 minute.
5. The message “PRECIP IDENT DATA AVAILABLE” must continue to be displayed in a constant intensity, high contrast color.

3.8.2.7 Freezing rain sensor report processing requirements

Whenever Report Processing is turned off for the freezing rain (ZR) sensor or if the ZR sensor is reconfigured, the system must examine the user status to see if an OBS is signed on.

If an OBS is not signed on:

1. The system must delete the automated ZR remark and generate the remark ZRNO if the five-minute ambient temperature is less than or equal to 36 degrees F or is missing, until report processing is turned back on or the ZR sensor is reconfigured.
2. The remark ZRNO must not be appended if the five-minute ambient temperature is greater than 36 degrees F.

If an OBS is signed on:

1. The remark ZRNO must not be generated. The words “ZR DATA N/A” must be flashed in a high contrast color for a period of 1 minute on the bottom of the one-minute screen. The message “ZR DATA N/A” must continue to be displayed in a constant intensity, high contrast color, until report processing is turned back or the sensor is configured or enabled.

2. When the ZR sensor is configured, enabled, and contains no data quality errors, the system must remove ZRNO from the remarks.
3. Whenever the ZR sensor is restored, and the OBS is logged on, the system must announce the restoration of the present weather identifier data by flashing the words: “ZR DATA AVAILABLE”, on the bottom of the one-minute screen.
4. The message “ZR DATA AVAILABLE” must continue to be displayed in a constant intensity, high contrast color.

3.8.2.8 *ADAS port reconfigured or disabled signed on requirements*

Whenever the ADAS port is reconfigured or disabled, the system must examine the user status to see if an OBS or an ATC is signed on

If an OBS or an ATC is not signed on:

1. The system must automatically generate the remark TSNO until ADAS is configured or enabled, and valid thunderstorm data is received from the network.
2. The TSNO must appear in the remark field on the one-minute screen and in the METAR.
3. The maintenance flag “\$” must not be generated for TSNO.
4. Whenever the ADAS port is configured and enabled and lightning data is being received, the system must remove “TSNO”.

If an OBS or an ATC is signed on:

1. The remark TSNO must not be generated.
2. The maintenance flag “\$” must not be generated.
3. The bottom of the one-minute screen must display the words: “TSTM DATA N/A”. Note: Under no circumstance must the present weather field of the METAR contain a “TS” or “VCTS” when a TSNO is present.
4. The system must notify the user of restoration of the thunderstorm data by flashing the words “TSTM DATA AVAILABLE” on the bottom of the one-minute screen on the OID, and sounding an audible alarm on the OID.
5. The message “TSTM DATA AVAILABLE” must continue to be displayed in a constant intensity, high contrast color.

3.8.2.9 *Observers signed on functions requirements*

Through the OID, only observers who are signed on must be able to perform the following functions:

1. Generate specials using the current One-Minute Data.
2. Transmit specials early, (i.e., eliminate the time available for edit prior to transmission).
3. Cancel any pending special observation.
4. Augment selected parameters, which must remain on the screen and in subsequent observations until the next METAR is processed or until superseded by an automated value.
5. Edit any parameter thereby placing the automatic processing of that parameter in manual mode, leaving the sensor in operation (i.e., sensor data remains accessible for review via the OID function). Note: Edited parameters must remain in manual mode until the next METAR is processed with the exception of present weather, altimeter, and tower visibility, after which the parameter must revert to automatic processing.
6. If only the algorithmic output has been placed into manual mode, (i.e. through an edit function) the parameter must revert to the automated processed value.
7. If the sensor status or report processing has been turned off, (i.e., through sensor configuration change) the edited parameter must revert to missing. (i.e., "M").
8. The "M" on the screen should be highlighted and an alarm must sound for a maximum of 1 minute.
9. All edited elements must be preceded by an asterisk on the display to indicate manual intervention. Manually edited data must be processed through all algorithms needing that particular data, including monthly and daily summaries.
10. The operator must be able to retrieve the last transmitted message, make any necessary change, place "COR" in the heading of the METAR observation message and retransmit the METAR message.
11. This "corrected" observation must then be retransmitted and archived again by the system. The editing of this message must have no affect on the One-Minute Data.

12. The Observer must be able to cancel a “COR” message if desired.
13. An ABORT key and XMIT key must be provided on a separate keypad below the CMD-OBS-COR screens.
14. When the ABORT key is pressed, the “COR” observation message must be canceled, and the system must return to the one-minute screen.
15. If the XMIT key is pressed, the “COR” observation message must be transmitted, and the system must return to the one-minute screen.

3.8.2.10 Air Traffic Controllers signed on requirements

Through the OID, the air traffic controllers who are signed on must be able to:

1. View sensors in manual mode.
2. Edit the present weather.
3. Enter and remove tower visibility.
4. Enter additional remarks.
5. Select the message for voice output, i.e., One-Minute Data or last METAR/SPECI observation transmitted.
6. Control the recording/erasing of messages via the microphone.
7. Generate specials.
8. “Hot Keys” must be provided to expedite the generation and transmission of specials for
 - a. Tornado,
 - b. Thunderstorm,
 - c. Hail,
 - d. Remarks for virga,
 - e. Volcanic ash, as an obstruction to vision or as a remark.
9. Review functions must be limited to REVUE RPT OBS, REVUE RPT 5-MIN and REVUE SENSR STAT.

3.8.2.11 Technicians OID functional requirements

Through the OID, technicians must be able to perform the following functions:

1. Change system configuration including:
 - a. Sensors (e.g., primary vs. secondary visibility)
 - b. Display devices (OID, VDU, Video interface)
 - c. External communications
 - d. Voice output
 - e. FDCUs
2. Switch from one message format to another on the same port.
3. Change communications port characteristics such as parity, baud rates, etc.
4. Generate entries in the maintenance log.
5. Select digitized voice message to be broadcast, either current One-Minute Data or last METAR/SPECI observation transmitted.
6. Execute system diagnostics and tests.
7. Query the release number and data of the installed operational software.
8. Set system clock.
9. Review the results of system diagnostics and tests.
10. Enable and disable communications ports.
11. Change dialing mode between pulse and tone.
12. Change selected site constants.
13. Reset TDAU hardware and software

3.8.2.12 System managers OID functional requirements

In addition to those functions accessible at the technician level, system managers must be exclusively able to perform the following functions:

1. Assign and change access code and passwords.
2. Change selected site criteria, such as specials/local criteria.
3. Commission long-line communication of weather products (remove test criteria from METAR messages).

4. Commission voice (remove test identifier from automated voice message).

3.8.3 OID Interface additional requirements

The following are additional requirements, which apply to the OID interface.

3.8.3.1 *GENOB*

1. Upon selection of tornadic event, the system must automatically place/remove the event in present weather and generate the begin/end remark.
2. All times used to describe event begin/end times must be two-digit unless the hour in the remark is different from the hour of the pending observation message.
3. If the hour of the event begin/end time is not the same as the current hour, the remark must be a four-digit UTC time.
4. A remark key must be available for the operator to enter additional remarks.
5. After exiting, the operator must be able to re-enter GENOB and add remarks thereby causing the generation of another tornadic SPECI, which would be a continuation of the existing event.
6. Remarks must be placed at the beginning of the remark field.
7. On the GENOB keypad display, change the "EXIT" key to read "XMIT". When leaving the GENOB function by pressing the "XMIT" key, the question "DO YOU WANT TO TRANSMIT (Y or N)" will be displayed if a SPECI has been generated. IF this prompt is answered "Y", the SPECI will be released for transmission, and the display revert to the one-minute screen. Answering "N" must delete the SPECI and return the user to the one-minute screen. No default action should be taken in responding to this question (i.e. answering anything other than "Y" or "N" will result in the questions being asked again).

3.8.3.2 *Hot Keys*

1. Five hot keys must be provided to expedite the generation and transmission for tornado, specials for thunderstorm and hail, remarks for virga, and the inclusion of volcanic ash as an obstruction to vision or remark.
2. The hot keys must only be displayed and enabled while an air traffic controller is logged on.
3. The identity of the hot keys must be clearly labeled on the OID screen along with abbreviations to describe their functionality.

4. The hot keys must act as toggle switches to append or delete the appropriate entries in the present weather/obstructions to vision or remark. SPECIs must be automatically generated as required. Hot keys will be implemented for the five phenomena listed in the table below:

Table 3.8.3.2-1 – OID Hot Keys for ATC User

Weather Type	Present Wx	Remark	Remark
Tornado / Waterspout / Funnel Cloud	“+FC/FC”	TORNADO B01E16	Special
Thunderstorm	“TS”	TSB05E22	Special
Hail	“GR”	GRB00E18	Special
Virga	None	VIRGA	None Req.
Volcanic Ash	”VA”	None Req.	None Req.

5. To prevent accidental transmittal of a SPECI message, the user must respond “Y” to a “YOU HAVE SELECTED THE XXXXX HOT KEY. ARE YOU SURE (Y/n)”. If the user responds “N” to the prompt, no changes to the present weather and remarks fields occur.
6. In order to expedite the transmission of messages generated with hot keys, no remark editing must be provided.
7. All event begin/end times must be two-digit (minutes past the hour) except when the hour of the event begin/end is not the same as the valid hour of the automated weather observation message.
8. In those cases, a four-digit UTC time (HHMM) must be used.

3.8.3.3 *EDIT Mode*

1. Place manual remarks (which include tornadic remarks) ahead of automated remarks.
2. When necessary to stay within the 150-character limit, automated remarks must be truncated.
3. Provide ATC access to tower visibility when the observer is signed on.
4. When in EDIT, automatically display the auxiliary elements.
5. The operator, i.e., the observer or controller, must be able to enter a parenthetical remark in an observation message, which must not be transmitted as a part of the observation message but is archived.

6. During the METAR EDIT TIME, the operator must be able to delete automated remark(s) prior to transmission of the observation message. This deletion has no affect on further sensor processing.
7. The first line of the present weather field must be 22 characters long.

3.8.3.4 *REVUE Mode*

1. Provide a menu key within all revue functions to allow the operator to move up one level at a time.
2. In the 12-hour data file, provide information on the status of photometers separately from the visibility sensors. If the visibility sensor is missing and the photometer is missing, both should be indicated as such.
3. In REVUE SENSR DATA and 12-HR change the presentation of precipitation identification data when the sensor is reading “NP” to show “NP”.
4. In REVUE SITE PHYSICAL the length of the field for magnetic declination should allow for three digits plus sign (e.g. E/W).

3.8.3.5 *REVUE SITE VERSN SENSR*

1. Allow all users except ATC the capability to view the current version of firmware for each sensor.
2. The format and layout of this page must be similar to the REVUE SITE CONFIG DEFIN page.
3. The page must list all sensors currently configured on the system, with the current version of firmware clearly listed after each sensor.
4. The technician must have the capability to manually enter the sensor version firmware number on this page.

3.8.3.6 *SIGN*

1. When an observer or air traffic controller signs on, change the system identifier (used in the observation message) by removing the word “AUTO” from the observation.
2. When an observer or air traffic controller are not signed on, the observation must contain the word “AUTO”.
3. ATC users must not automatically be signed off at station closing or after the nine-hour time-out.

3.8.3.7 *MISCELLANEOUS*

1. Operator time entries for data retrieval must not require entry of the colon, e.g., 10:15:35.
2. In addition to the LST time, on the OID display, the UTC must be provided in hours and minutes with the “Z” designator, e.g., 2315Z.
3. a.bcUser commands or function keys must be provided to allow the observer, technician, and system manager to extract a selected range of products (e.g., METAR for specified date and time). The following must be available:
 - a. OBS file (Date/Time Selection)
 - b. 12-HR (Date/Time Selection)
 - c. SYSLOG (Numeric Error Code extraction selected by Date/Time)

3.8.3.8 *TWR VISIBILITY FUNCTION*

Retain the last tower visibility value entered into the system until that value is either changed or deleted by the ATC or observer.

3.8.3.9 *MAINT*

1. The maintenance flag (“\$”) must not be set when loss of AC power to either the TDAU or FDCU occurs.
2. baThe maintenance flag (“\$”) must be set for FDCU/TDAU communications failures only when one or both of the following conditions occurs:
 - a. Degraded Mode - TDAU/FDCU communications failures on any link exceed 20% since the failure counts were last reset at 0600 LST.
 - b. Hard-Fail Mode - Communications failures are detected continuously for a full minute on any FDCU/TDAU communications link.
3. At 0600 LST, the fail communication from FDCU maintenance screen must be reset to zero. All information presented on the screen must be accessible remotely.
4. bThe maintenance flag (“\$”) for modem loop back failures and for SIO loop back failures must be set.
5. cThose failures for each modem and SIO loop back failure must be automatically entered in the SYSLOG at time of detection.

3.8.3.10 d

ADAS Summary Screen

1. The ADAS summary screen, accessible via the MAINT function, must provide an hour-by-hour listing of the occurrence of the following status codes for the last 24 hours:
 - a. ADAS HAS STARTED POLLING THE SYSTEM (SP)
 - b. SYSTEM HAS LOST POLL FROM ADAS (LP)
 - c. ADAS-AWSS LINK ESTABLISHED (LNK)
 - d. ADAS HAS DISCONNECTED FROM AWSS (DIS)
2. All information presented on the ADAS summary screen must also be accessible remotely.

3.9 Video Display Units (VDU)

1. Display(s) of the One-Minute Data and METAR messages must be provided.
2. The VDUs must continuously display the current one One-Minute Data and METAR messages in accordance with the format specified in the AWSS Software Users Manual (SUM).
3. The VDUs must be desk-mounted.
4. VDUs must be capable of operating up to 8 miles from the TDAU.
5. The VDUs must be readable by a person with normal (corrected to 20/20) vision in levels varying from normal room lighting to near darkness, at angles up to 45 degrees to the plane of the display, and at a distance of 6 feet.
6. The VDUs must be a minimum of 12 inches diagonal. The VDUs must be capable of displaying 40 characters per line on a minimum of 16 lines.

3.10 External Communication Interfaces

External communications consist of all asynchronous and synchronous data communications from the TDAU to various users. The data must be in final format and must consist of observations, archival data, remote maintenance monitoring information, and data quality checks.

3.10.1 General Requirements

The communications subsystem hardware functional configuration is shown in Figures 3.10.1-1 and 3.10.3-1.

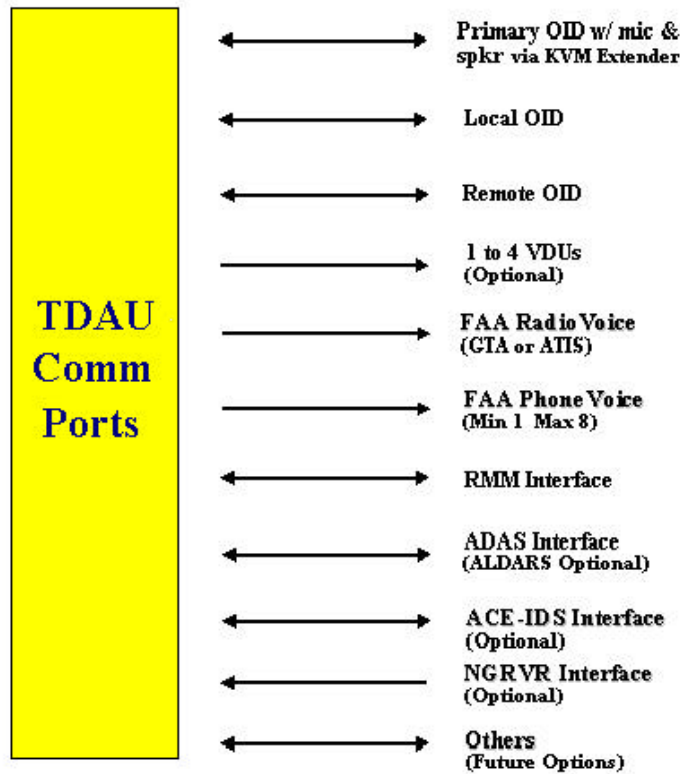

5

Figure 3.10.1-1 Functional Configuration – TDAU Communications Ports

1. 6The AWSS must simultaneously serve all users (current and future) described in the paragraphs that follow. Configuration of the system will vary in accordance with the Site Table.
2. 7Changes in communications requirements at any site must be accommodated by one or more of the following methods: changes in site constants; insertion or extraction of a circuit card (or card set); attachment or removal of cables; and/or in some case addition or deletion of other vendor furnished equipment.
3. 8The AWSS must interface with:
 - a. aFAA up-link for voice broadcast
 - b. Dedicated and dial phone lines (voice and digital data)
 - c. RS-232 bus configuration or equivalent
 - d. Twisted pair cable or equivalent
 - e. Coaxial cable or equivalent

3.10.2 Telephone Interfaces

1. The contractor must supply dial-in telephone interfaces: for the remote maintenance monitoring facility, and servicing requests for information.

2. bThe dial-in interface must be protected against unauthorized use with an access code.
3. cPassword for the 4 user types (OBS, ATC, TEC, and SYS) must be provided.

3.10.3 OID Port

1. aThis port must be used to transmit minute-by-minute data (including METAR, local and special observations) and all requested data to the OID.

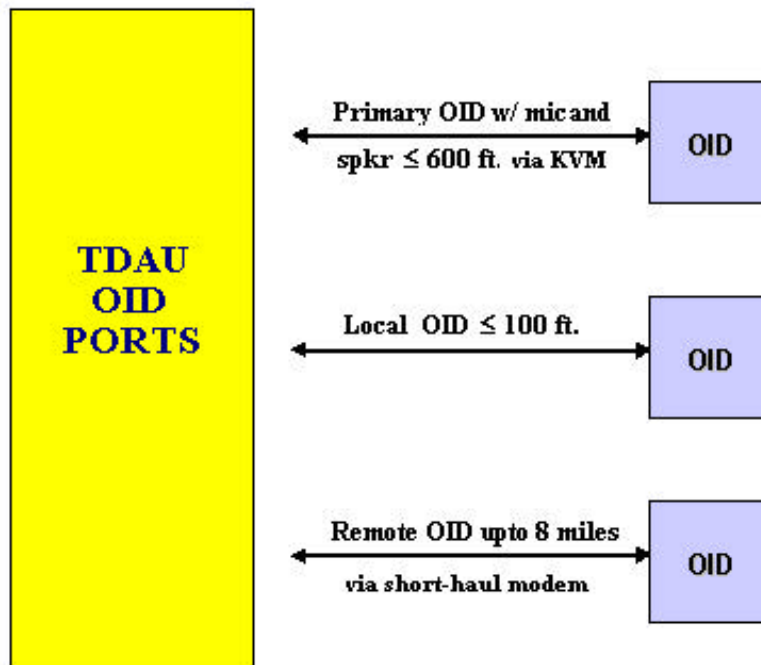

b

Figure 3.10.3-1 Functional Configuration – TDAU OID Ports

2. cThis port must service one local OID and two additional OIDs located at a distance up to 8 miles from the TDAU.
3. dThe operator comments must be accepted by the system immediately and must be included in the next complete voice message.
4. eMicrophone and speaker cabling must be separate from OID cabling.
5. The speaker must have a volume control adjustable from -0 to +70 dB.

3.10.4 aLocal VDU Port

1. bThe system must communicate with up to four separate VDUs simultaneously.
2. cOne-Minute Data, METAR and SPECI messages must be transmitted via the local VDU port.

3.10.5 FAA-Digitized Voice/Radio/Telephone/Speaker & Microphone

1. aThis must be a voice-driven analog output port capable of interfacing both dial-up telephone and dedicated lines.
2. bThe TDAU must produce a computer-generated voice message from the digital weather product for continuous broadcast on all three ports.
3. cUp to 90 seconds of manual voice input must be digitally recorded in the TDAU.
4. The TDAU must take the METAR or One-Minute Data and translate to voice in accordance with the ASOS Voice requirements.
5. dThe vocabulary unique to a site (e.g., station identifier) must be maintained in permanent storage. Voice control details are provided in the AWSS SUM.
6. The characteristics of the voice generator are:
 - a. aA microphone must control the operation of this voice interface.
 - b. bA voice generator must store the latest weather observation in memory, compose a voice message from a stored vocabulary, and output the data to a voice generator for conversion to speech.
 - c. A voice generator must receive data words from the microprocessor and convert them to an analog signal representing speech.
 - d. Message memory of the voice unit must be able to accommodate a 60 second observation and a 90 second NOTAM.
 - e. aThe voice message must be generated continuously, with a 5 ± 1 second delay between the completion of one weather observation and the beginning of the next.
 - f. bIf a voice message is transmitting and new weather data is received, the current message must complete without interruption.
 - g. Voice quality must be in accordance with the ASOS Voice Vocabulary Requirements document.

- h. The voice output must indicate that the sensor parameter is missing during a sensor malfunctions.

3.10.6 Voice generator interfaces requirements

The voice generator interfaces to both eight dial-up telephones lines and a dedicated circuit used to produce a ground-to-air radio broadcast. The telephone interface must have the following attributes:

1. Answer by end of second ring.
2. Voice output commences within five seconds, in mid-message if necessary; and the output must continue no longer than 190 seconds \pm 10 seconds, followed by an automatic hang up.
3. A counter must be included to count and report the total number of incoming calls each 24 hours (0000 – 2359 hours).

3.10.7 Automated/manual voice balance output requirements

1. The radio interface must be driven by a balanced low impedance driver providing a nominal one-milliwatt of power into a 600-ohm line.
2. The output must be adjustable from 0 to –12 dB, with a nominal 0-dB output.
3. In addition, the combination of automated voice with manual voice must produce a balanced output such that the volume level is consistently even for the entire voice message.
4. The voice output and the voice input must be transmitted on a dedicated connecting cable that connects the TDAU to the OID (See Figure 3.10.3-1). The dedicated connecting cable must be separate from the OID data cable.
5. The physical characteristics and quality of the dedicated connecting cable must be equivalent to those of an unconditioned-switched network telephone line.

3.10.8 FAA ADAS

1. The FAA AWOS Data Acquisition System (ADAS) port must be a synchronous input/output port capable of sending and receiving weather messages to the FAA ADAS.
2. The TDAU must extract and process the information from the database and translate it into the ADAS format prior to transmission.

3. 9Transmission must be in accordance with the current revision of the ADAS/AWSS-ASOS-AWOS Interface Control Document (ICD) NAS-IC-25083101A.

3.10.9 Remote OID Port

1. 11The Remote OID port must be an interactive, asynchronous dial-in port with the capability to support all remote OID functions and to send/receive information such as the minute-by-minute weather data, requested data, maintenance data, communication log, and diagnostics test results in accordance with the AWSS SUM.
2. 12The Remote OID port must be able to support a wide range of common communication applications including, but not limited to, collecting weather data to running remote diagnostics by technicians.
3. 13The Remote OID port must be compatible with:
 - a. 14a COTS ANSI terminal that is not restricted to one manufacturer; and
 - b. an OID (with modem); and
 - c. a PC using COTS communications software.

3.10.1015 NGRVR Interface

1. 16At selected sites the TDAU must provide an interface to the NGRVR computer.
2. 17The system must accept the RVR message and process it.

3.10.1118 ACE-IDS Interface

1. At selected sites, the TDAU must provide an interface to the ACE-IDS Processor.
2. 19The system must provide the necessary data to the ACE –IDS in accordance with the current revision of the ACE-IDS/AWSS ICD.

3.10.1220 Other Ports

Additional ports must provide expansion capability. The system communications output processor must accommodate all additional ports. Specific requirements do not exist; therefore spare ports are defined in terms of their similarity to existing ports. For testing purposes similar means identical. The port requirements are:

1. 21Similar to OID (1 port required)

2. Similar to FAA ADAS, including modem (1 port required)
3. Similar to Remote OID port (1 port required)
4. Similar to NGRVR (1 port required)
5. Similar to RMM port, serial data

3.10.13 Ground to Air Radios

1. 22A Very High Frequency (VHF) Amplitude Modulated (AM) transmitter must be provided for the voice broadcast of the weather data generated by the system for use in the National Airspace System (NAS).

2. The transmitter must operate in the range of 118-137 MHz with a 25 kHz

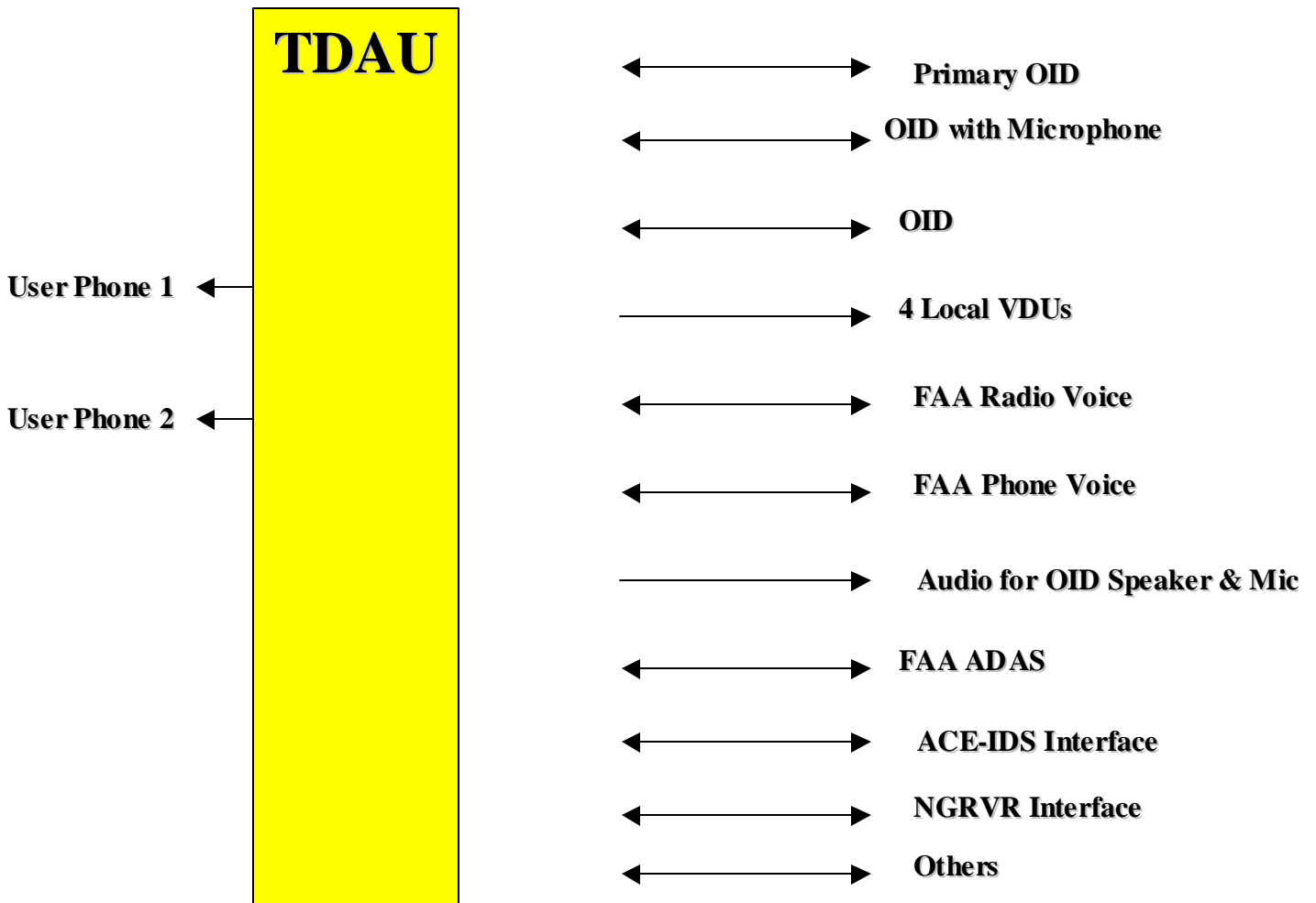

Figure 3.10-1 Communication Ports Functional Configuration

channel spacing capability.

3. The transmitter must operate on a frequency assigned by the FAA with a nominal power output of 2.5 watts.
4. The transmitter must meet the following technical requirements:
 - a. Channel Spacing: The channel spacing must be 25 kHz.
 - b. Transmitter Warm Up: The transmitter must be capable of meeting the requirements of full power operation within 30 seconds of being turned on.

- c. aTransmitter Audio: There must be provisions for a remote (balanced 600 ohms) audio signal.
- d. bTransient Protection: The transmitter must contain protection devices in the antenna circuits to protect the output stages of the RF amplifier of the transmitter from destructive transients originated by lightning, static or other transient sources.
- e. cVoltage Standing Wave Ratio (VSWR): The transmitter output circuitry must include protection against transmitter circuit damage due to an open antenna circuit, shorted antenna circuit and all complex reactive impedances between an open to shorted circuit.
- f. dRF Power Output: The continuous wave (CW) RF carrier output without modulation must be adjustable from 1 to 10 watts, measured at the antenna connector on the transmitter, terminated in a 50 ohm load.
- g. eFrequency Stability: The transmitter frequency instability must not exceed $\pm 0.0005\%$ of the operating frequency for each frequency selected.
- h. fSpurious Radiation: When measured at the transmitter RF output connector, the level of each spurious frequency must be greater than 80 dB below the level of the carrier at all modulation levels up to 90%.
- i. gOccupied Bandwidth: The transmitter occupied bandwidth must be such that no less than 99% of the modulated signal energy must be contained within a 25 kHz bandwidth (± 12.5 kHz of any selected channel frequency). No more than 0.5% of the radiated power must be contained in frequencies more than 12.5 kHz above and below the channel frequency.
- j. hAudio Compression and Limiter Circuits: The transmitter must contain audio compression and limiting circuitry designed to prevent over modulation of the carrier under all conditions and to retain a modulation level of 90% ($\pm 10\%$) under a variable audio input level from -25 dbm to +10 dbm.
- k. iModulation: Modulation method must be double sideband AM voice.
- l. jDistortion: The harmonic distortion in the demodulated transmitter output must not exceed 10% at a carrier output level of 5 watts, modulated 90%, for all frequencies between 300 Hz and 3 kHz.
- m. Harmonic Distortion: When measured at the RF output connector the level of each harmonic frequency of the carrier must be greater than 70 dB below the carrier fundamental. This measurement will be at full carrier output power level and at a modulation level of 90%.

- n. aCarrier Noise Level: When measured at the RF output connector and the transmitter operating at a carrier level of 10 watts, the detected output voltage obtained from an unmodulated carrier must be at least 40 dB below the detected output voltage obtained from a carrier modulated 90% ($\pm 10\%$) with a 1 kHz test tone.
- o. bIntermodulation: The transmitter must utilize a design that discourages unwanted Intermodulation frequencies from being generated within devices of the transmitter. Intermodulation product levels transmitted must be more than 20 dB below the carrier output level.
- p. cDuty Cycle: The transmitter must be designed for 100% continuous unattended duty at the maximum rated carrier output.
- q. dAntenna RF Output: The RF output circuitry must be designed for connection to a 50-ohm nominal impedance coaxial cable.
- r. 1. 2. 3. 4. 5. VHF antenna and cabling: VHF transmission must be utilized Omni Directional antenna such as Antenna Product DPV-35 or equivalent. Antenna cabling must be RG-214.

1.1.1 LRU definition.

- s. Environmental Conditions: The transmitter must meet the following:
 - i. The environmental requirements must be the same as those specified for the TDAU if the transmitter is to be housed in the TDAU or in a remote housing located within a controlled environment.
 - ii. If the transmitter is to be located within an uncontrolled environment, the environmental requirements identified for the RDCU must also pertain to the transmitter.

1.1.2 Outdoor Enclosures

- t. Reliability: The radio must have a MTBF of at least 12,000 hours.
- u. Maintainability: The transmitter must meet the following:
 - i. The GTA transmitter must demonstrate a MTTR, which is less than 30 minutes at the 95% confidence level.
 - ii. The MTTR must include the time required to fault detect, fault isolate, remove and replace the faulty LRU and perform all required checkout and calibration of the transmitter.
 - iii. For the purpose of this requirement, LRUs must be defined as the radio and the components of the antenna path.
- v. Built In Test: The transmitter must meet the following:

- i. aThe transmitter must have the capability to perform continuous self-test and on demand self test.
 - ii. The continuous self-test must not interfere with normal operation of the transmitter.
 - iii. The continuous self-test must report the failed LRU in the system log. The on demand self test must be activated by the operator during fault isolation, calibration and diagnostic testing. The on demand self-test may be an off-line diagnostic test that provides fault isolation to failed LRUs that are unable to be tested during operation. During on-demand self test, no test signal must be transmitted on the airways. All self-tests are required to meet the 95% confidence factor.
 - iv. Self-test activity must be reported on a maintenance screen.
- w. b. Calibration and Periodic Maintenance: The transmitter must meet the following:
- i. cThe GTA radio must be designed to eliminate or minimize the need for manual equipment adjustments, alignments, calibrations and preventive maintenance.
 - ii. Preventive maintenance, as required, must not be necessary more frequently than every six months.

3.11 Hardware Design and Construction

3.11.1 aUninterruptible Power Supply (UPS)

1. bThe TDAU UPS system must be capable of operating critical components (i.e., the TDAU, OID, etc.) without interruption and without external power for a minimum of 20 minutes during outage of AC primary power.
2. cThe FDCU UPS system must be standalone unit capable of operating critical components (i.e., the FDCU, sensors, etc.) without interruption and without external power for a minimum of 10 hours during outage of AC primary power.
3. dIf the option of not providing heater power from the UPS to the Ceilometer when primary power fails is the design implemented, a signal must be transmitted to the Ceilometer that heater power is not being provided and must indicate that the primary power has failed.
4. When primary power is restored, the system must communicate to the Ceilometer that primary power has been restored.
5. aThe contractor must assess the heater power requirements for other sensors to determine whether the heater power may be turned off during a primary power outage with no degradation of performance.

6. bBatteries must be sealed types, requiring no routine maintenance.
7. cThe AWSS must contain the housing, batteries, mounting hardware, and other equipment required connecting the UPS to the equipment.
8. The UPS must simultaneously provide power to the equipment and charge the storage batteries from a 50% charge condition to a full charge within 6 hours after return of AC power.
9. aThe UPS must be capable of 20 complete charge/discharge cycles without loss of more than 10% or rated energy storage capacity.
10. bBITE must be provided to monitor the performance, condition, and status of the TDAU UPS.

3.11.2 cSpecial Packaging and Housing Considerations

1. dIndoor equipment must be packaged in a standard FAA 19-inch rack configuration.
2. eConnectors must be mounted on the rear of the assemblies.
3. fThe system must contain spare slots and connectors that are devoted to expanding the system data acquisition and communications capability as specified in Section 3.10.
4. gSystem packaging must provide the following:
 - a. hLRUs exceeding 30 lbs must be labeled.
 - b. Rack-mounted equipment must be serviceable from the front.
 - c. Circuit cards/modules must be keyed to prevent incorrect insertion.
 - d. Plug in circuit cards/modules must contain restraining devices to prevent unseating during shipment or handling.
 - e. System packaging must be modular permitting simple reconfiguration, expansion, and repair.
 - f. All connectors must be labeled inside and outside of the enclosures/raceways.
 - g. All labeling must conform to the current revision of FAA-G-2100.

3.11.3 iLRU definition

jThe LRU must be defined as the lowest level, field-replaceable unit that can normally be replaced without opening sealed enclosures. All LRUs and connections must be labeled.

3.11.4 kOutdoor Enclosures/Raceways

The following applies to all outdoor enclosures of electronic equipment and sensors:

1. aMust be made of a material that is resistant to corrosion, and
2. bAll enclosures must be Nema-4X 316 stainless steel.
3. cCables must be adequately shielded to prevent conducted or radiated interference signals. The levels are specified in Section 3.4.4.
4. Power and signal return must be configured to permit single-point grounding.
5. Connectors at cable ends must be environmentally protected from the elements, utilize Mil-Spec type aviation connectors, and conform to specification MIL-C-26482.
6. aCabling must have an outer protective jacket that is capable of being buried in the ground, and provides protection from deterioration due to light, freezing temperatures, sleet, snow, rain, wet soil, rodent damage, etc.
7. bUnderground cable must be encased in conduit.
8. 1Mating connectors must be environmentally protected for units that are exposed to the outside environment, must include a strain relief, and all spare connectors must have moisture proof dust covers.
9. 23Replacement of any circuit cards/modules must not require removal of interconnecting cables to other circuit cards/modules.

3.11.5 Safety Criteria - Personnel Hazards

1. 4Construction of the equipment, excluding self-powered equipment, must ensure that all external parts, surfaces, and shields, exclusive of antenna and transmission line terminals, are at ground potential at all times during normal operation. Any external interconnecting cable, where a ground is part of the circuit, must carry a ground wire in the cable terminated at both ends in the same manner as the other conductors.
2. In no case, except with coaxial cables, must the shield be depended upon for a current-carrying ground connection.
3. Antenna and transmission line terminals must be at ground potential, except for RF energy on their external surfaces.

3.11.6 aSensor Mounts and Towers

1. bAll sensor mounts and towers must meet OSHA requirements.
2. cMaintenance must be able to be performed by a single person, working at ground level.
3. The use of ladders or climbing devices must not be required.
4. Sensors mounted higher than six (6) feet above ground level must be mounted on folding, tilting, or telescoping masts or towers.

3.11.7 Wind Tower Marking and Lights

1. The AWSS wind tower must be designed with a light sensor to turn off the obstruction lights during daylight hours.
2. The wind tower obstruction lights must use a dual LED type.
3. Painting must be performed on the tower with six (6) alternating white and orange sections, ending with an orange section at the top of the tower.

3.11.8 Electrical Overload Protection

1. Devices such as fuses, circuit breakers, time-delays, cutouts, or solid-state current-interruption devices must be used to open a circuit whenever a fault occurs.
2. No over current protective device must be connected in series with any conductor that is grounded at the power source unless the device simultaneously opens all load conductors in the circuit and no pole operates independently.
3. Protective devices for wired-in equipment must be connected to the load side of the equipment power switch (main circuit power disconnect).
4. All fuses providing protection to the equipment must be located such that they are readily replaceable and located in a convenient, serviceable location.
5. Where fuses are used, a minimum of one extra fuse of each type and rating used must be supplied and attached to the applicable units of the equipment.
6. Panel-mounted fuse posts must permit renewal of fuses without use of tools.
7. All contractor-designed equipment must use circuit breakers.

8. The circuit breaker must provide a visual indication when the breaker is tripped.
9. Holding the switching device closed on an overload must not prevent tripping of the breaker.
10. Circuit breakers must not be used as switches.

3.11.9 Personnel Hazards

Toxic products and formulations must not be used for the manufacture of the AWSS system. No Class I, ozone depleting substance (ODS), must be used in manufacturing or cleaning of components, parts, or end items for the AWSS system. Class I ODS, agents are defined as chlorofluorocarbon, halon, carbon tetrachloride, and methyl chloroform. Contractor must exercise ODS requirements in accordance with 10 CFR 20 Regulations.

3.11.10 Grounding

The design and construction of the AWSS must ensure that all external parts, surfaces, and shields, exclusive of antenna and transmission line terminals are at ground potential at all times during normal operation. Any external or interconnecting cable, where a ground is part of the circuit, must carry a ground wire in the cable in the same manner as the other conductors. In no case, except with coaxial cables, must the shields be depended upon for a current-carrying ground connection. Antenna and transmission line terminals must be at ground potential.

Ground connections to shields, hinges, and other mechanical parts must not be used to complete electrical circuits. A point on the electrically conductive chassis or equipment frame must serve as the common tie point for static and safety grounding.

All grounding conductors must be routed as directly as possible without loops, excess length, or sharp bends. An equipment-grounding conductor provided and installed in accordance with the current revisions of FAA-STD-19 and FAA-STD-20.

3.11.11 Bonding

High quality bonding must be designed and incorporated into the AWSS and its installations in accordance with the current revisions of FAA-STD-19 and FAA-STD-20.

3.11.12 Shielding

Shielding must be provided to protect equipment and interface lines (all signal data, control, power lines, and cables) from lightning currents and discharges. Shielding must also be provided for the containment of interference and signals produced by equipment and to protect susceptible equipment from related environmental signals and interference in accordance with the current revisions of FAA-STD-19 and FAA-STD-20.

3.11.13 Flammable Materials

Unless otherwise specified herein materials that are not self-extinguishing, capable of supporting combustion, or that are capable of causing an explosion must not be used.

3.11.14 Moisture and Fungus

Materials resistant to moisture and fungus must be used whenever possible. Screws, bolts, slit-fits, screw threaded inserts, and press fits must be assembled using a suitable preservative to prevent corrosion and must comply with the current revision of FAA-G-2100.

3.11.15 Soldering

Assembly and soldering on the AWSS system must be in accordance with ANSI/J-STD-001B Class 3 or equivalent.

3.11.16 Electrical Overload Protection

Overload protection must be provided for the AWSS system. Devices such as fuses, circuit breakers, time delays, cutouts, or solid-state current interruption devices must be used to open a circuit whenever a circuit shorts. No over current protective device must be connected in series with any conductor which is grounded at the power source unless the device simultaneously opens all load conductors in the circuit and no pole operates independently, or as otherwise allowed by the current revisions of FAA-STD-19 and FAA-STD-20. All contractor-designed equipment must use circuit breakers that are readily accessible to the operator.

3.11.17 Electrical Connectors

Selection and use of electrical connectors must be in accordance with the current revision of FAA-G-2100. Contact crimp, installing, and removal tools must be in accordance with the current revision of FAA-G-2100 or as specified in the individual connector specifications. Power connections should be weather proof plugs with screw type connectors at the outside of the enclosure. However, the variety of tools required within a system must be kept to a minimum.

3.11.18 Occupational Safety and Health Administration (OSHA)

All AWSS components must comply with OSHA regulations and FAA standards and practices for equipment in ATCTs and terminal radar approach control facilities.

3.11.19 Maintenance Monitoring Capability

1. Local or remote maintenance monitoring must be performed on the AWSS.
2. The system must generate maintenance and system data that is viewed and acted upon with a local OID and remotely by a conventional alphanumeric ANSI terminal, not limited to any one manufacturer, or a personal computer with the proper communications software.
3. The following functions must be available:
 - a. System voltage check, when and where available
 - b. System temperature check, when and where available
 - c. Sensor status and out of tolerance conditions
 - d. Communications status

- e. Ability to turn off/on reporting of specific sensors
- f. System reconfiguration
- g. System reset (TDAU only)
- h. Run and results of self-test
- i. Remote diagnostics on communications and system functions
- j. Access to maintenance logs
- k. Trends and system test

3.11.20 Maintenance Data Format and Storage

1. Maintenance data must be automatically archived in a maintenance log for a minimum of 31 days and the current day's data.
2. The log must have the following format:
 - a. A Date and Time Group (in LST), followed by
 - b. An Entry Code (i.e. a unique numeric code for each type of log entry; the entry code will be used for computer monitoring of the AWSS maintenance status), followed by
 - c. The Log Entry (i.e. a brief explanatory text associated with each entry code. The log entry must be in understandable English text, but may use abbreviations.)
3. Log entries must, as a minimum, consist of the following:
 - a. Technician notes – three digits of the entry code must consist of the technician's initials.
 - b. Failures or suspected failures based on data quality checks or other self-tests- the suspect LRU or sub-LRU must be identified.
 - c. All system configuration changes, (i.e., removal or replacement of any LRU).
 - d. Restoration of malfunctions, (i.e., if any LRU, that has been reported as failed, begins to function properly.)

3.11.21 Communications Status Log

1. Communications status messages associated with ADAS, ACE-IDS, and NGRVR must be listed in a communications log (Commslog), entirely separate from the maintenance log (SYSLOG).
2. Memory space must be provided for listing a minimum of 200 entries, on a first in first out basic.
3. The Commslog must have the following format:
 - a. A Date and Time Group (in LST), followed by

- b. An Entry Code (i.e. a unique numeric code for each type of communications status condition), followed by
 - c. The Log Entry (i.e. a brief explanatory text associated with each entry code. The log entry must be in understandable English text, but may use abbreviations.)
4. Text must in understandable English, but may use abbreviations.
 5. The Commslog must not include WRITE capability.

4. VERIFICATION

4.1 General

Section 4 defines a set of qualification methods to be used to ensure that each requirement in Section 3 has been satisfied.

4.2 Responsibility for Verification

Testing of the AWSS First Article must be performed to ensure that the requirements specified in Section 3 are satisfied. The AWSS vendor is responsible for developing test plans and procedures, as identified in the Statement of Work (SOW).

4.3 Verification Method

Verification methods include Demonstration (D), Analysis (A), Test (T), and Inspection (I).

Verification by Demonstration (D) involves verification through a non-instrument test, where success is determined from observation alone. Included in this category are tests whose results can be easily determined on a pass-fail basis.

Verification by Test (T) involves systemic exercising of an item under all appropriate conditions; along with the collection, analysis, and evaluation of quantitative data for predetermined performance characteristics. Acceptability is determined by the comparison of the data with pre-established quantitative requirements and occurrences.

Verification by Analysis (A) involves technical/mathematical evaluation or simulation using mathematical representations and representative data to prove that specified requirements are met. Representative data may include data collected from previous or other equipment and system verification.

Verification by Inspection (I) involves verification by visual examination of the item, reviewing descriptive documentation and comparing the appropriate characteristics with a

predetermined or referenced standard, to determine compliance with requirements, without the use of special laboratory equipment or procedures.

4.4 Verification Program

The AWSS verification program must be conducted in four phases:

1. Factory Acceptance/First Article Test (FA/FAT)
2. Development Test (DT)
3. Operational Test and Evaluation (OT&E)
4. Site Acceptance Test (SAT)

The contractor will conduct FA/FAT to assure that the First Article AWSS system satisfies the functional requirements specified in Sections 3 is satisfied. The contractor will develop the test plans and procedures for the conduct of FA/FAT.

Workmanship requirements for the First Article AWSS system, specified in Section 3, will be verified during the SAT portion of OT&E, using contractor-developed test plans and procedures. Human factors requirements for the First Article System will also be tested during OT&E, using FAA-developed SAT procedures.

Production AWSS units will be subject to a Production Acceptance Test at the vendor's facility prior to acceptance by the FAA's Quality Representative, to ensure that specification requirements are met on all production units. Contractor-developed Production Test Procedures will be a subset of FA/FAT, to ensure that the production hardware performs IAW specification requirements.

Workmanship requirements for each production AWSS unit will be verified at the SAT, conducted at that site.

5. PACKAGING

The package requirements must be as specified in MIL-STD-2073

6. NOTES

(This section contains information of a general or explanatory nature, which may be helpful, but is not mandatory.)

6.1 Intended Use

N/A

6.2 Acquisition Requirements

Acquisition documents must specify the following:

1. Title, number, and date of this specification
2. The specific issue of individual documents referenced in this specification
3. Packaging, handling, and shipping requirements.

6.3 Associated Data Item Descriptions (DIDs)

N/A

6.4 Technical Manuals

The requirement for technical manuals should be considered when this specification is applied on a contract. If technical manuals are required, specifications and standards must be listed on a separate Contract Data Requirements List (CDRL), which is included as an exhibit to the contract.

APPENDIX A

Acronyms

A	
AC	Alternating Current
ACE-IDS	ASOS Controller Equipment-Information Display System
ADAS	AWOS Data Acquisition System
ALDARS	Automated Lightning Detection and Reporting System
AM	Amplitude Modulation
A _o	Operational Availability
ASOS	Automated Surface Observing System
ATC	Air Traffic Controller
ATCT	Air Traffic Control Tower
AUX	Auxiliary
AWOS	Automated Weather Observing System
AWSS	Automated Weather Sensor System
B	
BIT	Built-in tests
bps	Bits Per Second
C	
CE	Conducted Emission
COTS	Commercial Off The Shelf
CS	Conducted Susceptibility
CW	Continuous Wave
D	
dB	Decibel
E	
EMI	Electromagnetic Interference
F	
FAA	Federal Aviation Administration
FDCU	Field Data Collection Unit
FC	Foot-Candles
G	
GHz	Giga Hertz
GTA	Ground To Air
H	
Hg	Mercury

Hz	Hertz
I	
ICD	Interface Control Document
I/O	Input/Output
K	
KHz	Kilo Hertz
L	
LRU	Line Replaceable Unit
M	
METAR	International Aviation Routine Weather Report Format
MHz	Mega Hertz
MMDT	Mean Maintenance Delay Time
MOT	Mean Outage Time
MOLDT	Mean Other Logistics Delay Time
MSRT	Mean Supply Response Time
MTBF	Mean Time Between Failure
MTTR	Mean Time To Repair
N	
NAS	National Airspace System
NGRVR	New Generation Runway Visual Range
NWS	National Weather Service
O	
OBS	Observer
OID	Operator Interface Device
OSHA	Occupational Safety & Health Administration
P	
PC	Personal Computer
PWINO	Present Weather Information Not Available
R	
RE	Radiated Emission
RF	Radio Frequency
RFI	Radio Frequency Interference
RI	Report Increment
RMA	Reliability, Maintainability and Availability
RMM	Remote Maintenance Monitoring
RMSE	Root Mean Square Error
RS	Radiated Susceptibility

SSPECI
SUMSpecial Report
Software User's Manual**T**TDAU
TS
TSNOTerminal Data Acquisition Unit
Thunderstorm
Thunderstorm Data Not Available**U**UHF
UPS
UTCUltra High Frequency
Uninterruptible Power Supply
Universal Coordinated Time**V**VCTS
VDU
VHFThunderstorm in Airport Vicinity
Video Display Unit
Very High Frequency**Z**ZRNO
ZRFreezing Rain Information Not Available
Freezing Rain