

Model 1249-B Wind Direction Calibrator

User's Manual

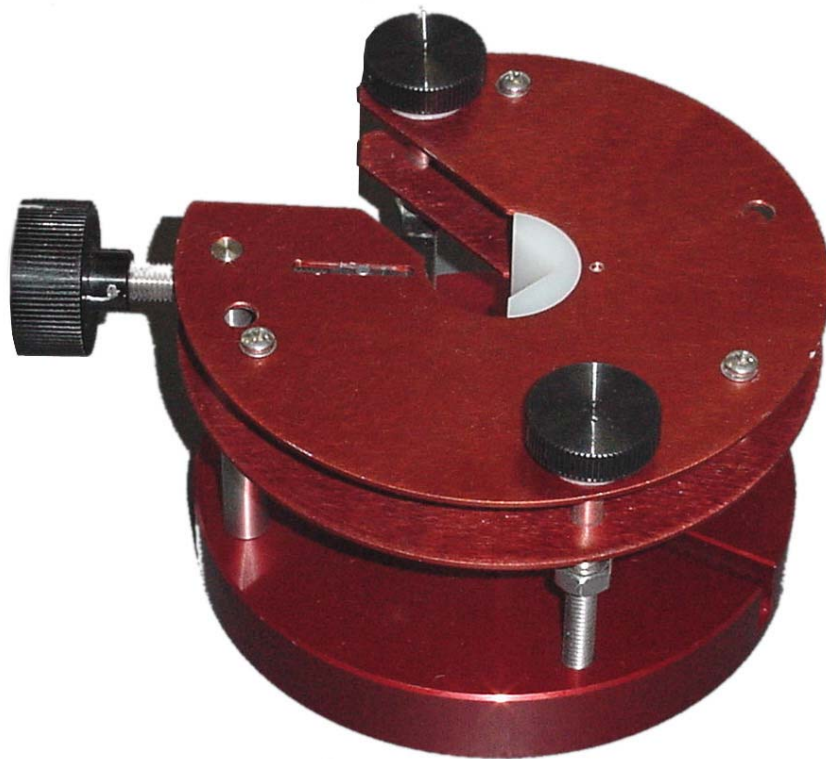

**WIND DIRECTION CALIBRATOR
MODEL 1249-B**

1.0 INTRODUCTION

- 1.1 The Model 1249-B Wind Direction Calibrator is a mechanical device that provides four calibration points (each 90° apart) for testing the Model 2020 Micro Response Wind Vane. The assembly is ideal for stabilizing the vane's tail during initial installation and orientation, and also provides a 90° change when calibrating a system with a standard deviation module. The Model 1249-B is designed for use when the Model 2020 vane is mounted to a fold-over tower and the tower is lowered (in a horizontal position).
- 1.2 The calibrator is made of anodized aluminum and stainless steel to resist against corrosion and provide durable, long term use.

2.0 SPECIFICATIONS

Type	Wind direction
Calibration points	4 at 90° increments
Operations	Manual
Power requirements	None
Accuracy	± 2 degrees
Size	5" dia. x 3.25" high (127 mm x 83 mm)
Weight/Shipping	2.0 lbs./3.0 lbs. (.91 kg/1.36 kg)

3.0 INSTALLATION

- 3.1 This instrument is thoroughly tested and fully calibrated at the factory and is ready for installation. Please refer to the return authorization card included in the packing box if damage has occurred. Also, notify All Weather Inc. NOTE: The calibrator can be installed onto the vane without any alteration to the vane assembly.
- 3.2 Separate the two halves of the calibrator by loosening the two thumbscrews and pulling the two discs apart.
- 3.3 Take the half of the calibrator with the knurled knob, and slip the unit onto the stationary portion of the vane's housing near the rotating cap. Loosen the knob, if necessary, to do this; then tighten the knob until the unit is secured.
- 3.4 Hold the tail shaft and place the top half of the calibrator onto the shaft and sensor cap. Notice that the top half is recessed to accommodate the counter weight, and that there is a groove for the tail shaft and a cut out for the top of the vane cap.
- 3.5 Rotate the top plate until the two pins are aligned with the holes in the bottom plate. The bottom half of the calibrator may require adjusting if it is too high or too low on the vane housing. Loosen the knurled knob and position the bottom half as needed.
- 3.6 Gently tighten the two thumbscrews to secure the top half of the calibrator to the bottom half. Do not overtighten.

- 3.7 Locate the alignment grooves inscribed onto the housing and cap of the vane. These two grooves must be aligned prior to proceeding with calibration. Loosen the knurled knob slightly and rotate the entire calibration unit along with the sensor tail until the two marks are aligned. Securely tighten the knurled knob.
- 3.8 Take a reading of the sensor output. Since the transducer is a shorting potentiometer, the vanes exhibit an output of either 0 or 5000 ohms at the alignment position. Any modules or indicators should show either zero or full scale at this position.
- 3.9 Loosen the two thumbscrews, lift the top half of the calibrator and rotate it and the vane tail 180°. Tighten the thumbscrews and take the next reading.
- 3.10 Loosen the two thumbscrews and remove the top half of the calibrator. Reposition the two alignment pins to the adjacent holes. Replace the top half of the calibrator and take the next reading.
- 3.11 Loosen the two thumbscrews, lift the top half of the calibrator and rotate it and the vane tail 180°. Tighten the thumbscrews and take the next reading.
- 3.12 Remove the calibrator by loosening the two thumbscrews, lifting off the top half, and then loosening the knurled knob to remove the lower half.

4.0 THEORY OF OPERATION

- 4.1 The wind direction calibrator is designed to provide a 4 point cardinal calibration with accuracy and repeatability.
- 4.2 The plates of the calibrator are machined and drilled on a precision mill giving a location accuracy of the pins and holes of ± 1 degrees. The tolerances of the shaft grooves and cap cut out increase the error of the alignment to give an overall accuracy of ± 2 degrees.

5.0 CALIBRATION

- 5.1 The Model 1249-B is not adjustable other than as described in Section 3.0. If a unit is out of calibration due to damage or to faulty construction, it should be returned for repair or replacement.

6.0 MAINTENANCE

- 6.1 Maintenance of the calibrator is limited to cleaning and occasional lubrication of rotating points. Store the calibrator in a dry location to reduce the possibility of corrosion.

7.0 DRAWINGS

- 7.1 Assembly drawings are included at the back of this manual to assist in the installation and maintenance of this instrument.

8.0 WARRANTY

8.1 Unless specified otherwise, All Weather Inc. (the Company) warrants its products to be free from defects in material and workmanship under normal use and service for one year from date of shipment, subject to the following conditions:

- a. The obligation of the Company under this warranty is limited to repairing or replacing items or parts which have been returned to the Company and which upon examination are disclosed, to the Company's satisfaction, to have been defective in material or workmanship at time of manufacture.
- b. The claimant shall pay the cost of shipping any part or instrument to the Company. If the Company determines the part to be defective in material or workmanship, the Company shall prepay the cost of shipping the repaired instrument to the claimant. Under no circumstances will the Company reimburse claimant for cost incurred in removing and/or reinstalling replacement parts.
- c. This warranty shall not apply to any Company products which have been subjected to misuse, negligence, or accident.
- d. This warranty and the Company's obligation thereunder is in lieu of all other warranties, express or implied, including warranties of merchantability and fitness for a particular purpose, consequential damages, and all other obligations or liabilities.

No other person or organization is authorized to give any other warranty or to assume any additional obligation on the Company's behalf, unless made in writing and signed by an authorized officer of the Company.

NOTES: UNLESS OTHERWISE SPECIFIED;
 1. PRESS ITEM (1) ONTO ITEM (15) WITH VISE OR ARBOR PRESS UNTIL FULLY SEATED.

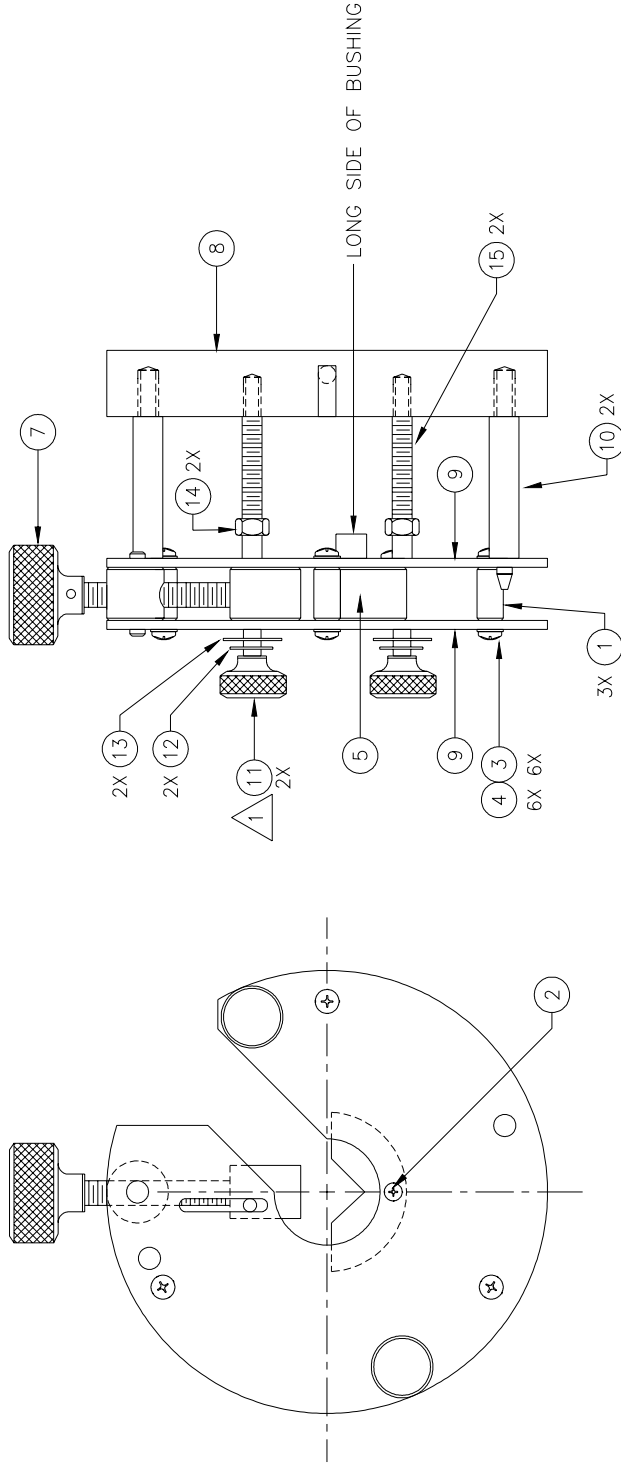

REV	ECO	DESCRIPTION	DWG NO.	1249-B03
A	4971	INITIAL RELEASE	DATE	APPROVED

APPEND THE FOLLOWING DOCUMENTS WHEN CHANGING THIS DOCUMENT:	UNLESS OTHERWISE SPECIFIED: DIMENSIONS ARE IN INCHES TOLERANCES XX=±.010 ANGLES ±1/2" XXX=±.005 CONCENTRICITY .003 TIR DO NOT SCALE DRAWING	DRAWN BY:	4/24/03	TITLE	ASSEMBLY DRAWING, MODEL 1249-B VANE CALIBRATION DEVICE FOR 2020-A
		P.K.		allweatherinc	
		REVISED BY:		SIZE	C
		CHECKED BY:		DWG NO.	
	MATL	DESIGN ENGINEER:		SCALE	1/1
	FINISH	PROJECT MANAGER:		RELEASE DATE	
	TREATMENT	AS ISSUED		DATE	
		APPROVALS		SHEET	1 OF 1

EXCEPT AS MAY OTHERWISE BE SPECIFIED BY CONTRACT, THIS DOCUMENT AND THE DATA DISCLOSED HEREIN AND HEREWITH, IS NOT TO BE USED, REPRODUCED OR DISCLOSED, IN WHOLE OR IN PART, TO ANYONE WITHOUT THE WRITTEN PERMISSION OF ALL WEATHER INC.

REV	ECO	DATE	DESCRIPTION
A	4971		INITIAL RELEASE

DWG NO.	1249-B05
REVISIONS	
DATE	1249-B05
APPROVED	

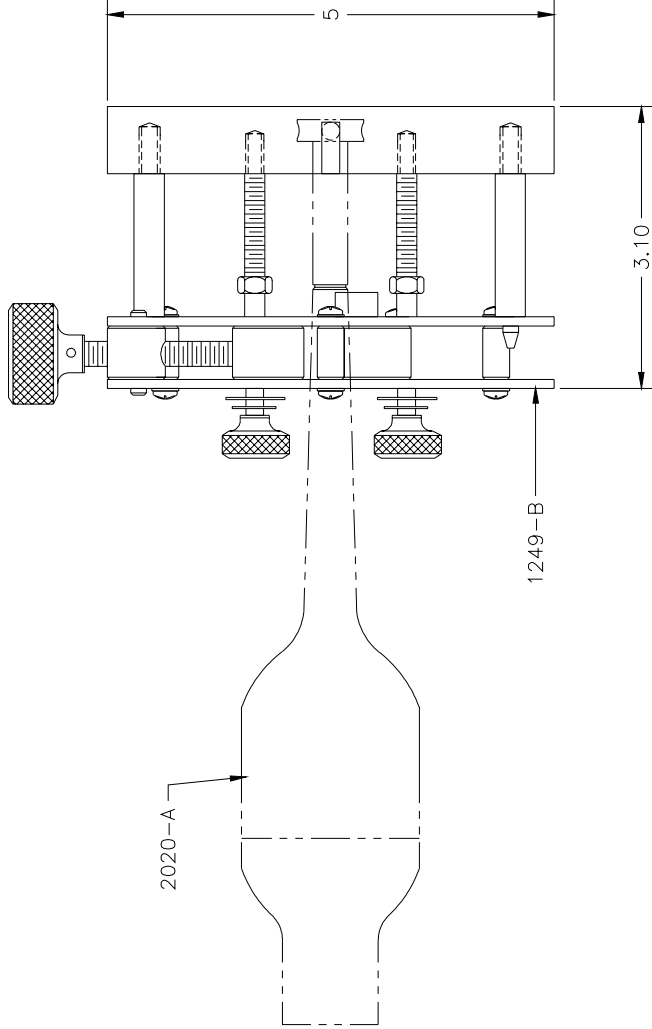

	
OUTLINE DRAWING, MODEL 1249-B VANE CALIBRATION DEVICE FOR 2020-A	
TITLE DWG NO. C	DWG NO. 1249-B05
SCALE 1/1	RELEASE DATE
SHEET 1 OF 1	DATE
APPROVALS	DATE
DRAWN BY: P.K.	4/24/03
REVISED BY:	
CHECKED BY:	
DESIGN ENGINEER:	
PROJECT MANAGER:	
UNLESS OTHERWISE SPECIFIED: DIMENSIONS ARE IN INCHES TOLERANCES XX±.010 ANGLES ±1/2° XXX±.005 CONCENTRICITY: .003 TIR DO NOT SCALE DRAWING	
APPEND THE FOLLOWING DOCUMENTS WHEN CHANGING THIS DOCUMENT:	
MATL SEE BILL OF MATERIALS	
FINISH AS ISSUED	
TREATMENT	

EXCEPT AS MAY OTHERWISE BE SPECIFIED BY CONTRACT, THIS DOCUMENT AND THE DATA DISCLOSED HEREIN AND HEREWITH, IS NOT TO BE USED, REPRODUCED OR DISCLOSED, IN WHOLE OR IN PART, TO ANYONE WITHOUT THE WRITTEN PERMISSION OF ALL WEATHER INC.



allweatherinc

All Weather Inc.

1165 National Drive

Sacramento, CA 95834

800.824.5873

916.928.1000

www.allweatherinc.com

ECO 4971
May, 2003