

# Micro Response Anemometer Model 2031



User's  
Manual



1165 National Drive • Sacramento, CA 95834 • 800.824.5873

---

# Introduction

The Model 2031 Micro Response Anemometer is a highly responsive three cup anemometer that uses a DC generator to produce a DC voltage output proportional to wind speed.

- The threshold of the anemometer is 1 mile per hour.
- The entire anemometer assembly, with the exception of the DC generator, is made from stainless steel and anodized aluminum.
- A quick release waterproof connector is provided.

The Model 2031 Anemometer is often used in conjunction with signal conditioning modules or data acquisition systems. Signal conditioning modules provide an analog output proportional to wind speed. Data acquisition systems can be directly coupled to the Model 2031 to provide instantaneous as well as averaged wind speed data.

---

# Contents

- Installation ..... 1
  - Assembly ..... 1
  - Site Selection ..... 1
  - Mounting ..... 2
  - Orientation ..... 2
  - Connection ..... 2
- Theory of Operation ..... 3
- Calibration ..... 4
- Maintenance ..... 5
  - Maintenance Kit ..... 6
- Warranty ..... 7
- Specifications ..... 8
- Drawings ..... 9

# Installation

This instrument is thoroughly tested and fully calibrated at the factory and is ready for installation. Please refer to the return authorization card included in the packing box if damage has occurred. Also, notify All Weather, Inc.

## Assembly

With the exception of installing the cup assembly, the Model 2031 Micro Response Anemometer is ready for mounting. Install the cup assembly as described in the steps below.

Loosen the two No. 6 allen set screws and slide the cup assembly over the anemometer shaft. Be certain that the flat face of the shaft faces toward the set screws.

The cup assembly hub should slide down over the shaft and body and seat against the shaft ring. When correctly in place, there should be about a 0.050 inch clearance between the skirt of the hub and the shoulder of the body. Tighten both set screws.

Spin the cup wheel by hand to assure smooth operation. The cup wheel should coast to a smooth stop.

## Site Selection

Location of the sensor is critical for accurate wind measurements. The standard exposure of an anemometer or vane over open, level terrain is 10

meters above the ground. Open, level terrain is defined as level ground with no obstruction within 300 meters. In locations where obstructions are not large, such as residential areas, and are distributed more or less evenly, the sensor may be placed at an effective height of  $h + 10$  meters, where  $h$  is the approximate height (in meters) of the various obstacles. As an example, in a location where trees and buildings reach to about 5 meters, the sensors must be placed on a 15 meter mast to avoid erroneous results.

In areas where large obstructions do exist within 300 meters of the sensor, the following table can be used to calculate the proper height of the sensor ( $h$  is the height of the obstruction).

*Example* If there is a building 10 meters high and 50 meters away, the anemometer should be at least 16.7 meters above the ground. But, if the same building is 200 meters away, the sensor could be lowered to 12.5 meters.

When the sensor is mounted on a building, the building itself disturbs the wind flow and must be taken into account before installation. For large buildings, other than buildings such as lighthouses and skyscrapers, the sensor must be mounted as far away from the edge of the building as possible and at a height **at least 3/4 the height of the building**. Thus, with a building 28 meters high, a rooftop tower at least 21 meters high should be used.

Distance to obstruction	Minimum height above ground level of anemometer
$h$	1.75h to 2.25h
5h	1.67h
10h	1.50h
20h	1.25h
25h	1.13h
30h	$h$

**Table 1<sup>1</sup>**

<sup>1</sup> Handbook of Meteorological Instruments, 2nd Edition. Measurement of Surface Wind, Volume 4. London, HMSO: 1981

## Mounting

The Model 2031 Micro Response Anemometer mounts directly to the Model 2023 Crossarm without any additional accessories. The crossarm is generally used to mount one each Model 2031 Anemometer and a Model 2020 Vane to form a wind speed and direction measurement set. If the Model 2031 Anemometer is to be mounted separately, a Model 20231 Mast Adapter should be ordered as an accessory. Both the Model 2023 Crossarm and the Model 20231 Mast Adapter will mount on a mast with an outside diameter of 1" (25.4 mm) or 3/4" Schedule 40 pipe. Set screws are provided in either case for securing to the mast. The lower part of the anemometer body will slip over the pin on the crossarm or the mast adapter. When in place, tighten all mounting screws.

## Orientation

The anemometer should be mounted with its axis as close to vertical as possible to provide for the best measurement of horizontal wind movement. If the sensor must be removed the sensor from the

mounting adapter or crossarm, loosen only the allen head screw on the sensor base and slide the sensor off the adapter. Do not remove the mounting pin from the crossarm or the mast adapter from the mast, since these serve to maintain sensor alignment.

## Connection

Pre-assembled cables in three lengths are available for connecting the 2031 to a data collection device:

Cable Number	Length
20305	25'
20306	50'
20307	200'

These cables are equipped with a mating connector on the sensor end and unterminated wires at the opposite end. Connect the unterminated wires to the data collection device as shown in Figure 1. (Note that only two of the cable's wires (BLACK and GREEN) are used.)

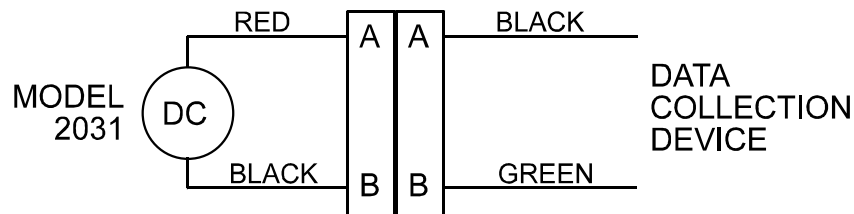

FIGURE 1

---

# Theory of Operation

The Model 2031 Micro Response Anemometer uses a miniature DC generator as a transducer. The shaft couples the cup assembly to the generator. The output of the generator is approximately 7.0 mV/mph. A small filter capacitor should be placed across the output lines to filter out any noise.

# Calibration

The output of the sensor can be determined by spinning the shaft at a known rpm and extrapolating the data from the chart in Table 2.

Calibration data in Table 2 has been developed from operating the anemometer in a wind tunnel equipped with NBS-traceable measuring instruments.

The Model 1200 Wind Speed Conditioning Module (when used) is equipped with a calibration feature consisting of a voltage divider circuit and a switch to apply the voltage to the signal conditioning circuitry. This feature allows the operator to quickly set up the output signals for zero and full scale values. Refer to the Model 1200 manual for additional information.

Whenever maintenance is performed on the anemometer or the generator, shaft, or bearings are replaced, the anemometer must be re-calibrated.

Spin the shaft at 1800, 600, and/or 300 rpm and measure the output voltage. If the value has changed, readjust the module input scaling voltages; or, if a data logger is used, recalculate the slope and intercept equation. The anemometer output will change whenever the generator is replaced due to variations between generators.

Model 2031 Micro Response Anemometer Serial No. \_\_\_\_\_

Shaft Speed rpm	Wind Speed mph	Wind Speed m/s	Output VDC
50	3.0	1.33	_____
60	3.5	1.55	_____
120	6.4	2.9	_____
300	15.24	6.8	_____
900	44.7	20.0	_____
1008	50.0	22.4	_____
1500	74.1	33.1	_____
1800	88.8	39.7	_____
2027	100.0	44.7	_____
2042	100.7	45.0	_____
2270	111.9	50.0	_____

**Table 2**  
**Calibration Table**

---

# Maintenance

The anemometer bearings should be inspected for wear periodically. The bearings are sealed and protected to prevent dirt and moisture from entering. With time, however, the seals will no longer prevent dirt from entering the bearing race and the bearings may fail. The bearings may be replaced in the field or the anemometer may be returned to All Weather, Inc. for servicing.

Since corrosion is the main problem associated with wind sensors, apply a thick coating of silicon lubricant to the connector shell after the connector is attached and in place. Also, use a noncorrosive lubricant such as bee wax on all screws and fasteners whenever disassembly of the sensor is required. The use of these lubricants will make servicing of the sensor easier and will prevent seizure of the fastening hardware. It is also advisable to apply lubricant to the mounting adapter surfaces prior to final sensor installation. A commercial grade lubricant recommended for use is DOOR-EASE, available at hardware and automotive stores. In addition to these precautions, check that the drain hole in the base of the sensor is free of debris so that water drains away rather than collecting within the sensor. Follow the steps below to replace the bearings in the field.

- 1 Loosen the two set screws on the cup assembly hub. Remove the cup assembly.
- 2 Remove the lower body section by removing three recessed 6-32 screws.
- 3 Remove the generator and mounting adapter from the anemometer housing by removing the 3 screws around the edge of the adapter. Lift both parts together. The generator is held in place by a set screw on the side of the adapter. Loosen the set screw. Push forward on the base of the generator until the generator and brush-coupler emerge from the large opening in the adapter. A set screw secures the brush-coupler to the generator shaft. Loosen the set screw and remove the brush coupler. Now the generator can be extracted from the mounting adapter. Use care to avoid damage to the generator wires. To fully replace the generator, unsolder or cut the wires from the 4-pin connector. Upon reassembly, resolder the wires (red to pin A, black to pin B) and coat the soldered portions of the wires with a waterproof sealing compound.
- 4 Remove the E-clip from the shaft at the top of the unit and slide the entire shaft down and out of the unit, taking care not to bend the shaft.
- 5 Lift the upper bearing out by working a knife edge under the flanged outer race. Do not use excess force or hammer the bearings.
- 6 Using a rod of about  $\frac{1}{4}$ " diameter passed down from the top, carefully knock the lower bearing out.
- 7 Clean all parts and install new bearings. Press the bearings in place by applying pressure to the outer race only. The bearing could be damaged by pressing against the inner race.
- 8 Reassemble all parts in the reverse order of disassembly. If the generator has been unsoldered from the connector, reroute the wires through the connector hole from the inside to the outside of the housing and resolder the wires to the connector pins A and B. Insert the shaft of the generator into the small end of the mounting adapter and carefully push it through to the other side.
- 9 Install the brush coupler onto the generator shaft. Secure the coupler set screw. Push the generator back into the mounting adapter and the end of the generator will sit inside the smaller end of the adapter. Place the generator so that it is either flush with the back edge of the adapter or extends beyond the edge of the adapter, between 0.000 and 0.300 inches. Secure the generator into place by tightening the set screw in the side of the adapter.

- 10** Locate the anemometer main shaft assembly. Place an E-clip into the groove adjacent to the wire prongs. Slide one or two spacer washers onto the shaft. These washers eliminate the movement of the shaft between the bearings. Place the lower housing bearing onto the shaft with the shoulder of the bearing case toward the wire prongs. Insert the top end of the shaft up into the housing from the inside of the housing. Holding the shaft in place, slide on the upper bearing and install the upper E-clip.
- 11** Check the shaft for easy, smooth rotation. Also check for end-to-end movement. If the shaft and bearings move in and out of the housing add more spacer washers. If there is no shaft movement or the rotation seems to be stiff or hampered, remove one or more of the spacers.
- 12** Upon installation of the shaft assembly, insert the generator and mounting adapter into the anemometer housing so that the shaft prongs insert into the brush of the brush-coupler. Make certain that the mounting adapter is seated into the anemometer housing. Rotate the shaft by hand and check for smooth operation. Also monitor the connector wires and make certain that there is an output voltage produced when the shaft is turned. Notice that rotating the shaft in the direction opposite to that of the cup assembly rotation will produce a negative output voltage. Secure the generator and mounting adapter assembly into the housing using 3 4-40 x 1/2" screws. Use split lock washers to lock the screws into place.

- 13** Install the connector into the housing if it has been removed and replace the lower housing onto the upper housing. Make certain that the housing O-rings are in position to assure sealing of the body.

- 14** Should there be any problems with the generator, it should be replaced. Check for proper voltage polarity prior to connecting the signal conditioning module to the new assembly.

Use great care in disassembly and reassembly of the sensor. Never use excessive force to make parts fit together. Over-tightening of fasteners will either break the fastener or damage the machined threads of the sensor.

Any difficulties encountered during servicing that are not correctable by the user should be referred to the All Weather, Inc. Customer Service Department.

## Maintenance Kit

A maintenance kit (P/N M488141) is available for the Model 2031 that provides the parts necessary for basic upkeep of the instrument. The kit includes those parts that are the most susceptible to wear, such as bearings and set screws. To order this kit, contact All Weather, Inc. and specify Part Number M488141.

---

# Warranty

Unless specified otherwise, All Weather Inc. (the Company) warrants its products to be free from defects in material and workmanship under normal use and service for one year from date of shipment, subject to the following conditions:

- a. The obligation of the Company under this warranty is limited to repairing or replacing items or parts which have been returned to the Company and which upon examination are disclosed, to the Company's satisfaction, to have been defective in material or workmanship at time of manufacture.
- b. The claimant shall pay the cost of shipping any part or instrument to the Company. If the Company determines the part to be defective in material or workmanship, the Company shall prepay the cost of shipping the repaired instrument to the claimant. Under no circumstances will the Company reimburse claimant for cost incurred in removing and/or reinstalling replacement parts.
- c. This warranty shall not apply to any Company products which have been subjected to misuse, negligence, or accident.
- d. This warranty and the Company's obligation thereunder is in lieu of all other warranties, express or implied, including warranties of merchantability and fitness for a particular purpose, consequential damages, and all other obligations or liabilities.

No other person or organization is authorized to give any other warranty or to assume any additional obligation on the Company's behalf, unless made in writing and signed by an authorized officer of the Company.

---

# Specifications

Threshold .....	1 mph
Accuracy .....	±0.15 mph or 1%
Distance constant .....	5 feet
Range .....	0-100 mph (0-45 m/s)
Shaft torque .....	0.05-0.06 ounces per inch
Cup material .....	Carbon/Graphite composite
Turning radius .....	3.8"
Body size .....	12"H x 2 <sup>3</sup> / <sub>4</sub> " diameter (305 x 70 mm)
Weight/Shipping .....	2.5 lbs/7 lbs (1.1 kg/3.2 kg)
Mounting .....	Direct to crossarm or with adapter to 1" (25.4 mm) O.D. mast
DC output .....	approx. 7.0 mV/mph

---

# Drawings

The following pages include reference drawings to assist in installation and maintenance of this instrument.

REVISIONS				DWG NO.
REV	ECN	DESCRIPTION	DATE	APPROVED
A	2756	SEE ECN FOR HISTORY	9-87	
B	4251	ADD LABELS, NOTES 1 THRU 10, HARDWARE & SCHEMATIC	10-1-93	SP
C	4538	DELETED ITEM 2, ADDED NOTE 11	21NOV95	KAH
D	5016	DEL IT-14 & SHOW AS P/O IT-17, DEL NOTE 2	4/03	PK

NOTES: UNLESS OTHERWISE SPECIFIED;

- 1 APPLY SILICONE GREASE TO O-RING.
- 2 DELETED
- 3 SOLDER WIRES FROM GENERATOR ITEM 3 TO RECEPTACLE ITEM 1. APPLY LIQUID "HUMISEAL" OR EQUIVALENT, TO SOLDER CONNECTIONS BEFORE COVERING CONNECTIONS WITH SHRINK TUBING ITEM 5.
- 4 INSTALL COUPLING ASSEMBLY ITEM 20 ON TO SHAFT OF GENERATOR ITEM 3 USING SCREW WHICH COMES AS PART OF ITEM 20. PROVIDE SPACING OF 1/16" TO 1/8" BETWEEN ITEM 20 AND ITEM 3.
- 5 INSTALL SPACERS ITEM 21 AS REQUIRED TO PROVIDE FOR SMOOTH ROTATION OF SHAFT WITHOUT EXCESSIVE END TO END MOVEMENT OF SHAFT. USUALLY 1 OR 2 SPACERS ARE SUFFICIENT.
- 6 POSITION GENERATOR ITEM 3 VERTICALLY INSIDE ADAPTER ITEM 15 TO INSURE A "ZERO" LOAD CONDITION OF SHAFT.
- 7 COAT SCREWS WITH "DOOREASE" OR EQUIVALENT(BEEWAX).
- 8 INSTALL RECEPTACLE ITEM 1 TO UPPER BODY ITEM 16 WITH LARGE KEYWAY OF RECEPTACLE TOWARD TOP OF ASSEMBLY.
- 9 INSTALL LABELS OPPOSITE RECEPTACLE. IDENTIFY AS MODEL 2031 AND SERIALIZE.
- 10 DO NOT INSTALL CUP ASSEMBLY ITEM 18 AT THIS TIME.
- 11 MATING CONNECTOR, T210003, NOT INCLUDED IN THIS ASSY.

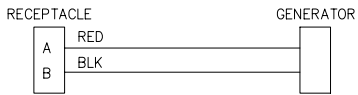
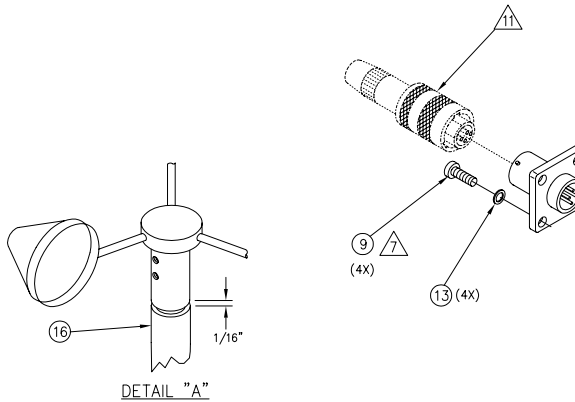
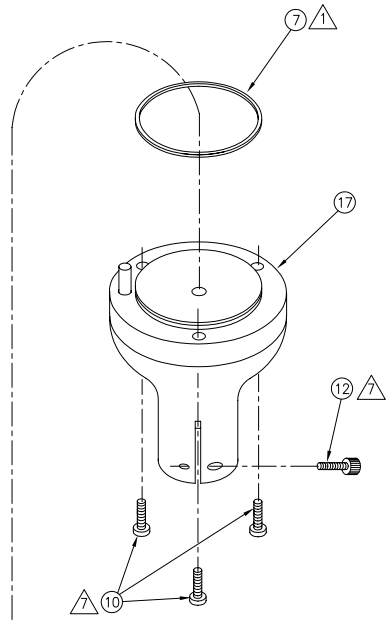
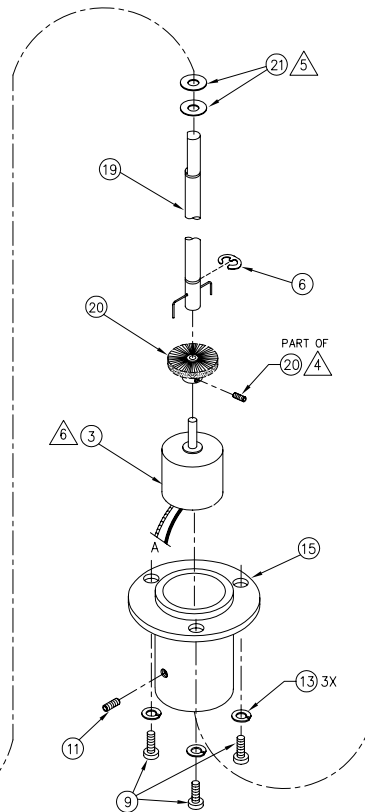
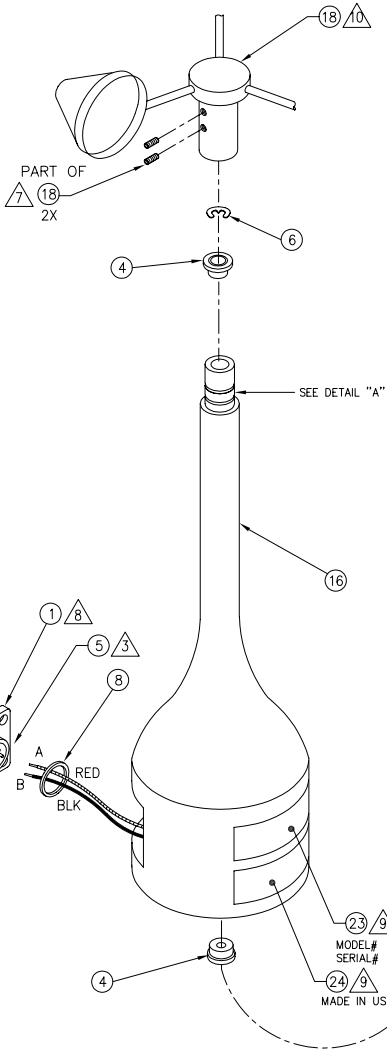

SCHEMATIC

EXCEPT AS MAY OTHERWISE BE SPECIFIED BY CONTRACT, THIS DOCUMENT AND THE DATA DISCLOSED HEREIN AND HEREWITH, IS NOT TO BE USED, REPRODUCED OR DISCLOSED, IN WHOLE OR IN PART, TO ANYONE WITHOUT THE WRITTEN PERMISSION OF ALL WEATHER INC.

APPEND THE FOLLOWING DOCUMENTS WHEN CHANGING THIS DOCUMENT: 2031-001		UNLESS OTHERWISE SPECIFIED: DIMENSIONS ARE IN INCHES TOLERANCES XX=±.010 ANGES ±1/2" XXX=±.005 FRACTIONS=±.02 DO NOT SCALE DRAWING		DRAWN BY: KOOYMAN 28JUL93		TITLE ASSEMBLY DRAWING, MICRO RESPONSE ANEMOMETER, D.C., MODEL 2031		
MATERIAL: SEE BILL OF MATERIALS		FINISH: AS ISSUED		CHECKED BY: J CONNER 21NOV95		DESIGN ENGINEER: J CONNER 21NOV95		
TREATMENT		PROJECT MANAGER:		APPROVALS		DATE		SCALE: NONE
SIZE: D		DWG NO.: 2031-003		RELEASE DATE		SHEET 1 OF 1		



**All Weather Inc.**

1165 National Drive  
Sacramento, CA 95818  
Fax: 916.928.1165  
Phone: 916.928.1000  
Toll Free: 800.824.5873

2031-001  
ECO 5245  
February, 2005