

# Model 3022 First Class Pyranometer

## User's Manual



# TABLE OF CONTENTS

INTRODUCTION .....	1
THEORY OF OPERATION .....	2
General Description .....	2
Accuracy .....	2
INSTALLATION .....	4
Location .....	4
Mounting .....	4
MAINTENANCE .....	6
CALIBRATION .....	7
SPECIFICATIONS .....	8
PARTS LIST .....	10

# INTRODUCTION

The Model 3022 pyranometer is designed for measuring irradiance (radiant-flux, Watt/m<sup>2</sup>) on a plane surface, which results from direct solar radiation and from the diffuse radiation incident from the hemisphere above. For measuring the diffuse component of solar radiation only, the direct solar component can be shielded semiautomatically from the pyranometer using the Model 30167 Shadow Ring.

The Model 3022 pyranometer complies with the specifications for “First Class”, which is second to “Secondary Standard” as published in the *Guide to Meteorological Instruments and Methods of Observation*, Fifth Edition, 1983, of the World Meteorological Organization (WMO)—Geneva, Switzerland. The WMO classification list is adopted, improved, and extended by the International Standard Organization (ISO) and published as ISO 9060.

# THEORY OF OPERATION

## General Description

The Model 3022 uses a thermal detector to measure solar radiation. This type of sensing element responds to the total power absorbed, and is theoretically nonselective as to the spectral distribution of the radiation. This implies that the naked thermal detector is also sensitive to long wave infrared radiation (thermal radiation >3000 nm) from the environment.

The radiant energy is absorbed by a black painted disk. The heat generated flows through a thermal resistance to the heat sink (the pyranometer body). The temperature difference across the thermal resistance of the disk is then converted into a voltage.

The temperature rise is easily affected by wind, rain, and thermal radiation losses to the environment (“cold” sky). Therefore, the detector is shielded by two glass domes. Glass domes allow equal transmission of the direct solar component for every position of the sun on the celestial sphere. The spectral range of the pyranometer is limited by the transmission of the glass. A desiccator in the body prevents dew on the inner side of the domes, which can cool down considerably on clear, windless nights.

## Accuracy

The pyranometer’s sensitivity is cross-correlated to a number of parameters, such as temperature, level of irradiance, vector of incidence, etc. The upper limiting values of the resulting sensitivity variations are listed in the specifications. The Model 3022 qualifies as “First Class” according to World Meteorological Organization classifications (see Table 1).

Characteristic	Secondary Standard	First Class	Second Class
Resolution (smallest detectable change in $W/m^2$ )	$\pm 1$	$\pm 5$	$\pm 10$
Stability (percentage of full scale, change/year)	$\pm 1$	$\pm 2$	$\pm 5$
Cosine response (percentage deviation from ideal at $10^\circ$ solar elevation on a clear day)	$< \pm 3$	$< \pm 7$	$< \pm 15$
Azimuth response (Percentage deviation from the mean at $10^\circ$ solar elevation on a clear day)	$< \pm 3$	$< \pm 5$	$< \pm 10$
Temperature response (percentage maximum error due to change of ambient temperature within the operating range)	$\pm 1$	$\pm 2$	$\pm 5$
Non-linearity (percentage of full scale)	$\pm 0.5$	$\pm 2$	$\pm 5$
Spectral sensitivity (percentage deviation from mean absorptance 0.3 to $3\mu m$ )	$\pm 2$	$\pm 5$	$\pm 10$
Response time (99% response)	$< 25$ s	$< 1$ min.	$< 4$ min.

Table 1. WMO pyranometer classifications.

The non-linearity error—the sensitivity variation with irradiance—is the same for any given 3022 (see Figure 1).

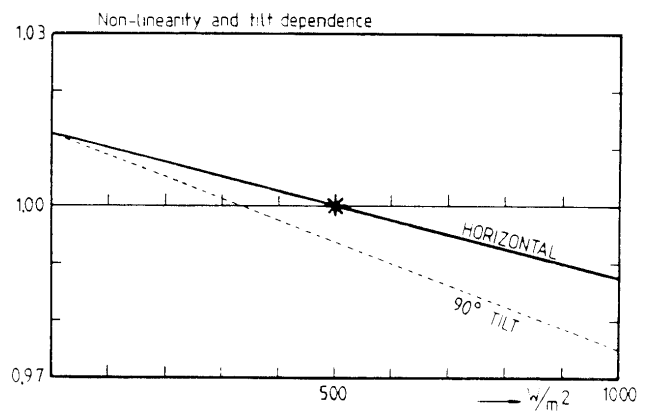

Figure 1. Non-linearity of Model 3022 pyranometer.

The temperature dependence of the sensitivity is an individual function. For a given 3022, the curve is somewhere in the shaded region of **Figure 2**.

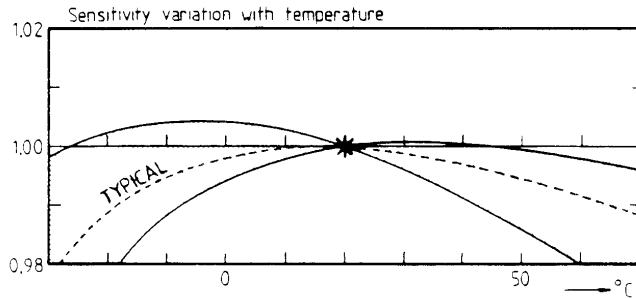

Figure 2. The curve of relative sensitivity variation with instrument temperature of a Model 3022 pyranometer is in the shaded region. A typical curve is shown.

Spectral selectivity is the product of spectral absorptance of the black coating and spectral transmittance of the glass domes (see **Figure 3**).

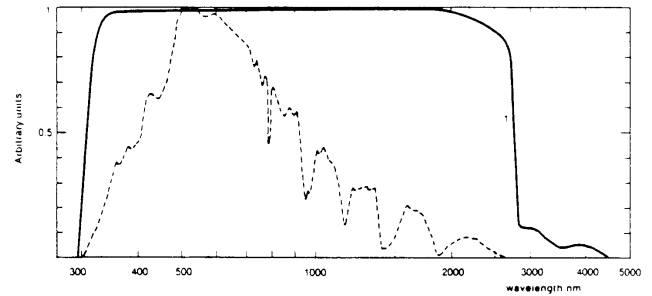

Figure 3. 1. Relative spectral transmittance of two pyranometer domes. (Four surface reflections and index change with wavelength are taken into account.)

2. Spectral distribution of solar radiation at sea level. Sun at zenith (Airmass 1).

# INSTALLATION

## Location

Ideally, the site for the pyranometer should be free from any obstructions above the plane of the sensing element and, at the same time, the pyranometer should be readily accessible to allow cleaning of the domes and inspection of the desiccator.

If this is not possible, the site should be chosen in such a way that any obstruction over the azimuth range between earliest sunrise and latest sunset should have an elevation not exceeding  $5^\circ$  (the apparent sun diameter is  $0.5^\circ$ ). This is important for accurate measurement of direct solar radiation. Diffuse (solar) radiation is less influenced by obstructions near the horizon. For instance, an obstruction with an elevation of  $5^\circ$  over the whole azimuth range of  $360^\circ$  decreases the downward diffuse solar radiation by only 0.8%.

The pyranometer should be located in such a way that a shadow will not be cast on it at any time (for example, by masts or exhaust pipes). Mind that hot (over  $200^\circ\text{C}$ ) exhausted gas (streams) will produce radiation in the spectral range of the 3022 Pyranometer. The pyranometer should be far from light-colored walls or other objects likely to reflect sunlight onto it.

## Mounting

In principle, no special orientation of the instrument is required due to the rotational symmetric sensor. The World Meteorological Organization recommends that the emerging leads are pointed to the nearest pole to minimize heating of the electrical connections.

Accurate measurement of global radiation requires proper leveling of the thermopile surface. Level the instrument by turning the leveling screws to bring the bubble of the spirit level within the ring. (For easy leveling, adjust the screw nearest the spirit level first.)

The pyranometer body should be thermally isolated from the mounting plate whenever possible. This can be done using the leveling screws. Electrical contact with ground must be maintained, however, to lead off current induced by lightning.

## Installation for Measurement of Reflected Solar Radiation

Reflected solar radiation can be measured by installing the Model 3022 in the inverted position. According to the WMO, the height should be 1-2 meters above a surface covered by short cut grass.

The mounting device should not interfere with the field of view of the instrument. A setup such as that shown in **Figure 4** is suitable. The upper screen prevents excessive heating of the pyranometer body by solar radiation, and, if large enough, will shield the lower screen from precipitation. The lower screen prevents direct illumination of the domes by the sun at sunrise and sunset.

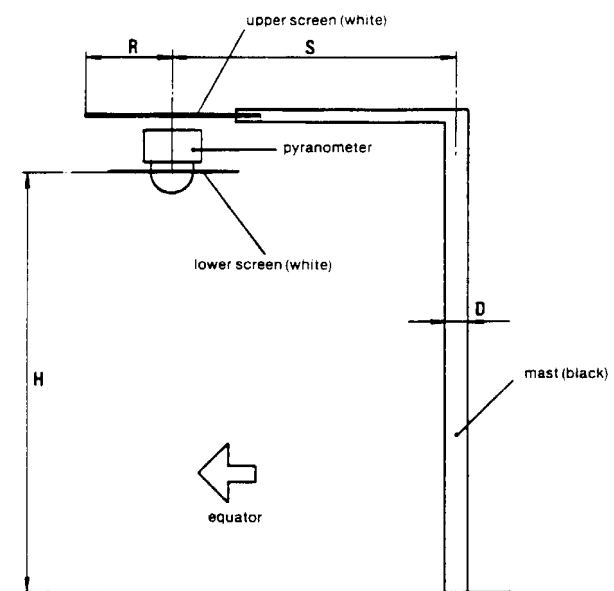

Figure 4  
Measuring Reflected Global Radiation

The mast shown in Figure 4 intercepts a fraction  $D/2pS$  of the radiation coming from the ground. In the most unfavorable situation (sun at zenith), the pyranometer shadow decreases the signal with a part  $R^2/H^2$ .

## Installation for Measurement of Diffuse Radiation

For measuring sky radiation, direct solar radiation is best intercepted by a small metal disk. The shadow of the disk must cover the pyranometer domes completely. However, to follow the sun's apparent motion, a power driven equatorial device is necessary.

Simpler is the use of a shadow ring (Model 30167). The shadow ring blocks direct radiation, allowing only diffuse radiation to reach the pyranometer. To compensate for seasonal changes, the shadow ring must be adjusted periodically.

## Electrical Connection

The Model 3022 is provided with a 10 meter cable with shield and three leads. The color code is:

red	plus
blue	minus
white	case

The shield is isolated from the case with a surge arrester, so no shield current can exist. Shield and white leads may be connected to the same ground at the readout equipment.

The pyranometer can be connected to a computer or data acquisition system as well. A low voltage analog input module with A/D converter must be available. The span and resolution of the A/D converter in the module must allow a system sensitivity of about 1 bit per  $W/m^2$ . More resolution is not necessary during outdoor solar radiation measurements, because pyranometers exhibit offsets up to  $\pm 2 W/m^2$  due to a lack of thermal equilibrium.

A surge arrester is incorporated into the sensor to lead off induced lightning current to the case. For this reason, the case should be grounded. The surge arrester is noble gas filled, has infinite impedance, and recovers after breakdown. The breakdown voltage is 90 V, and the peak pulse current is 10 kA.

Figure 5  
Model 3022 Electrical Connection

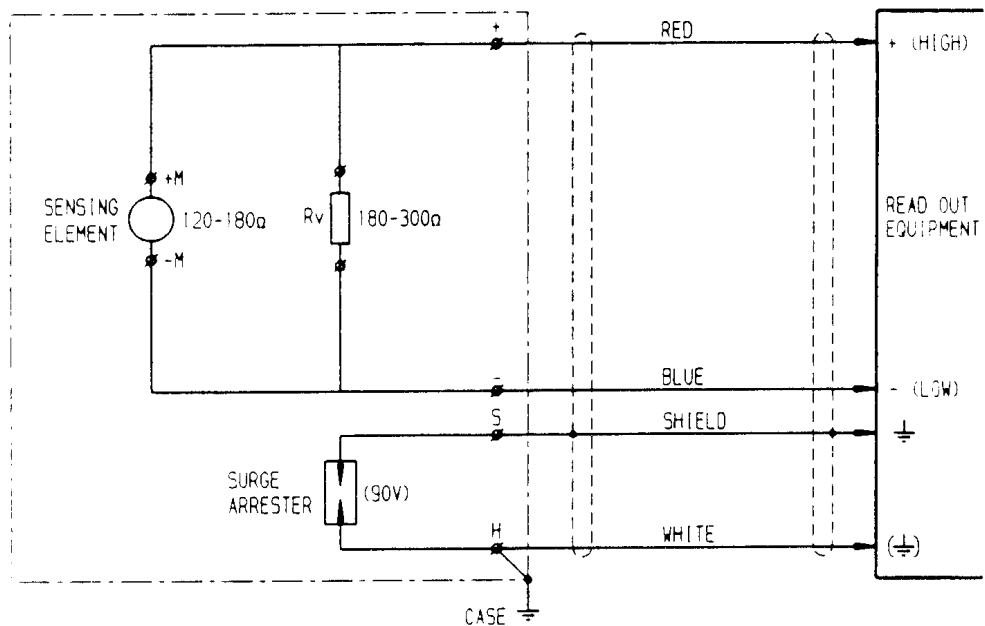

# MAINTENANCE

Once installed, the pyranometer requires little maintenance. The outer dome should be inspected at regular intervals and cleaned regularly, preferably every morning.

On clear windless nights, the outer dome temperature of horizontally placed pyranometers will decrease—even to the dew point temperature of the air—due to IR radiation exchange with the cold sky. (The effective sky temperature can be 30°C lower than the ground temperature, which results in an infrared emission of  $-150 \text{ W/m}^2$ .) When this happens, dew, glazed frost, or hoar frost may form on the top of the outer dome, and may remain there for several hours during the morning. An ice cap on the dome is a strong diffuser and increases the pyranometer's signal drastically, up to 50% in the first hours after sunrise.

In some networks, the exposed dome of the pyranometer is ventilated continuously by a blower to keep the dome above the dew point temperature. This ventilation also decreases the sensitivity to thermal radiation (zero offset I) by an approximate factor of two.

When the blue silica gel in the drying cartridge turns completely pink (normally after several months), it must be replaced with active material. Pink silica gel can be dried out and reactivated by placing it in an oven at 130°C for several hours.

# CALIBRATION

The ideal pyranometer should always have a constant ratio of voltage output/irradiance level (outside the instrument, in the plane of the sensing element). This ratio is called sensitivity or responsivity.

The irradiance value can be simply computed by dividing the output signal of the pyranometer by its sensitivity figure, or by multiplying the signal value by the reciprocal of the sensitivity figure (often called calibration factor).

The sensitivity figure of a particular pyranometer is an individual one, determined in the manufacturer's laboratory by comparison against a standard pyranometer.

Pyranometer sensitivity changes with time and with exposure to radiation, often due to deterioration of the black paint. Periodic calibration (at least every two years) is advised.

# SPECIFICATIONS

## Performance

Response time for 95% response	< 30 s
Zero offset	
a) response to 200 Wm <sup>2</sup> net thermal radiation (ventilated)	+15 Wm <sup>-2</sup>
b) response to 5 K h <sup>-1</sup> change in ambient temperature	±4 Wm <sup>-2</sup>
Non-stability percentage change responsivity per year	±1%
Non-linearity percentage deviation from the responsivity at 500 Wm <sup>-2</sup> due to the change in irradiance within 100 Wm <sup>-2</sup> to 1000 Wm <sup>-2</sup>	±1.2%
Directional response for beam radiation. The range of errors caused by assuming that the normal incidence responsivity is valid for all directions when measuring from any direction a beam radiation whose normal incidence irradiation is 100 Wm <sup>-2</sup>	±20 Wm <sup>-2</sup>
Spectral selectivity percentage deviation of the product of spectral absorptance and spectral transmittance from the corresponding mean within 0, 35 µm and 1, 5 µm	±2%
Temperature response percentage deviation due to change in ambient temperature from -10 to +40° C relative to 20° C	-2%
Tilt response percentage deviation from the responsivity at 0° tilt (horizontal) due to change in tilt from 0° to 90° at 1000 Wm <sup>-2</sup> irradiance	±1%
Viewing angle	2π sr
Irradiance	0-1400 W/m <sup>2</sup> (max 2000 W/m <sup>2</sup> )
Spectral range	305-2800 nm (50% points) 335-2200 nm (95% points)
Sensitivity	Between 9 and 15 µV/Wm <sup>-2</sup>
Impedance	70-100 Ohm

**Construction**

Receiver paint

Carbon black

Glass domes

Schott K5 optical glass 2 mm thick,  
30 mm and 50 mm outer diameter

Desiccant

Silica gel

Spirit level

Sensitivity 0.5 degree (bubble half out  
of the ring) coincide with base of the  
instrument. Detector surface and base  
are coplanar within 0.1°.

Materials

Anodized aluminum case, stainless steel  
screws in stainless steel bushes, white plas-  
tic screen of ASA, drying cartridge PMMA

Weight

850 g

Cable length

10 m

Dimensions

See **Figure 6**

Figure 6. Model 3022 First Class  
Pyranometer

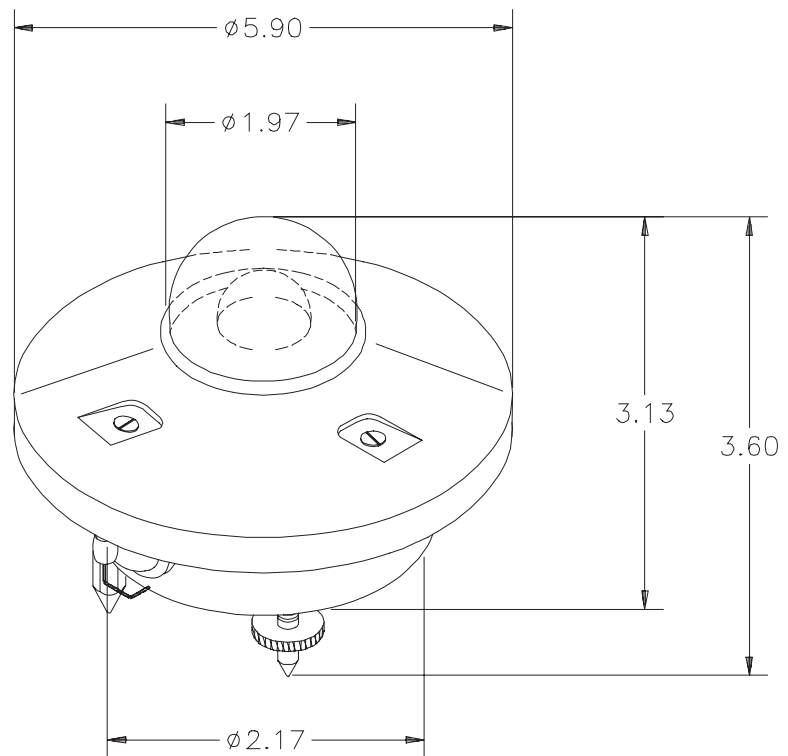

# PARTS LIST

## **Model 3022 Replaceable Parts and Options**

---

<i>Description</i>	<i>Part Number</i>
Desiccator cartridge	30161
White sun shield	30162
Rubber ring for outer glass dome	30163
Outer glass dome with metal ring	30164
Levelling screw	30165
Fixed mounting foot	30166
Shadow Ring	30167



**allweatherinc**

**All Weather Inc.**

1165 National Drive  
Sacramento, CA 95818  
Fax: 916.928.1165  
Phone: 916.928.1000  
Toll Free: 800.824.5873  
[www.allweatherinc.com](http://www.allweatherinc.com)

3022-001  
ECN 4476  
July, 1995