

Model 2020 Micro Response Vane

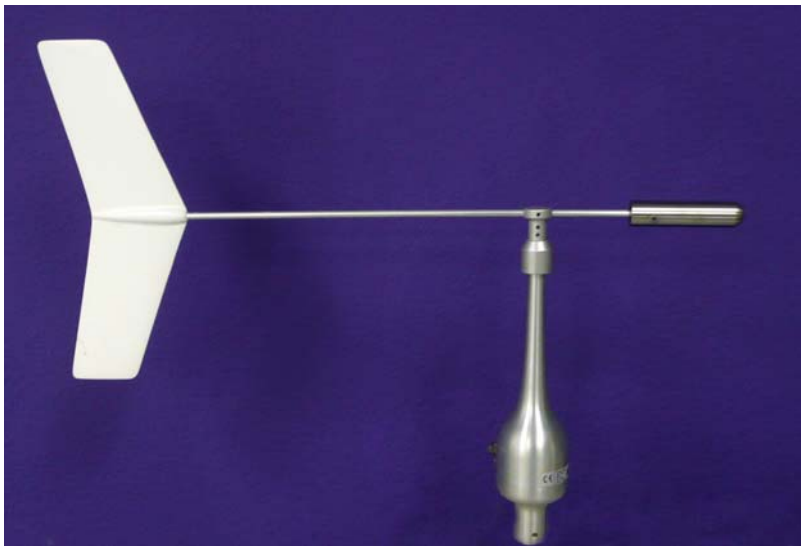

User's
Manual

Rev. P



Copyright © 2011–2015, All Weather, Inc.

All Rights Reserved. The information contained herein is proprietary and is provided solely for the purpose of allowing customers to operate and/or service All Weather, Inc. manufactured equipment and is not to be released, reproduced, or used for any other purpose without written permission of All Weather, Inc.

Throughout this manual, trademarked names might be used. Rather than put a trademark (™) symbol in every occurrence of a trademarked name, we state herein that we are using the names only in an editorial fashion and to the benefit of the trademark owner, and with no intention of infringement. All Weather, Inc. and the All Weather, Inc. logo are trademarks of All Weather, Inc.

Disclaimer

The information and specifications described in this manual are subject to change without notice.

Latest Manual Version

For the latest version of this manual, see the *User Manuals* page on our web site at <http://www.allweatherinc.com/support/support-library/user-manuals/>.



**All Weather, Inc.
1165 National Drive
Sacramento, CA 95834
Tel.: (916) 928-1000
Fax: (916) 928-1165**

Contact Customer Service

- **Phone** support is available from 8:00am - 4:30pm PT, Monday through Friday. Call 916-928-1000 and ask for "Service."
- **Online** support is available by filling out a request at www.allweatherinc.com/support/online-support/
- **E-mail** your support request to support@allweatherinc.com

TABLE OF CONTENTS

1. Introduction.....	1
1.1 Optional Heaters.....	1
2. Installation.....	2
2.1 Assembly.....	2
2.2 Site Selection.....	2
2.3 Mounting.....	3
2.4 Wind Direction Benchmark (AWOS Installations).....	3
2.5 Orientation.....	3
2.6 Connection.....	4
3. Theory of Operation.....	5
3.1 Definition.....	5
3.2 Theory of Operation.....	5
4. Calibration.....	6
4.1 Checking vane Operation.....	6
4.2 Alignment.....	6
5. Maintenance.....	8
5.1 Checking the Bearings.....	8
5.2 Precautions.....	8
5.3 Replacing the Bearings.....	8
5.4 Disassembly and Potentiometer Replacement.....	8
5.5 Maintenance Kit.....	9
5.6 Periodic Maintenance.....	9
5.6.1 Monthly Maintenance.....	9
5.6.2 Triannual Maintenance.....	9
5.6.3 Annual Maintenance.....	9
5.6.4 Verify Alignment Annually.....	9
6. Warranty.....	11
7. Specifications.....	12
8. Drawings.....	13

1. INTRODUCTION

The Model 2020 Micro Response Vane is a highly responsive analog-output wind vane. The vane body is precision-machined aluminum housing with a clear anodized finish. The structural plastic tail is protected with a durable aluminum-filled plastic coating. Stainless-steel shafts, bearings, and fittings are used throughout.

A precision potentiometer is coupled to the vane shaft to provide an analog output proportional to wind direction. A counterweight provides precision balancing of the tail assembly on the shaft. A quick-release waterproof connector is provided for cable terminations.

A mounting collar on the base of the vane body fits onto the Model 20231 Mast Adapter or the Model 2023 Crossarm. The 20231 Mast Adapter is used to install a single vane, while the 2023 Crossarm allows the Model 2020 Vane to be installed in combination with an anemometer, such as the Model 2030. Both the Crossarm and Mounting Adapter fit onto a pipe stub or mast with a 1" outside diameter.

1.1 OPTIONAL HEATERS

Optional heaters are available for use in cold climates to minimize shaft freezing. The heater assembly, which consists of a solid block of aluminum with a machined cavity containing a 20 W heater, mounts between the top and bottom sections of the vane body. The aluminum block acts as a heat sink, and the heater raises the block's temperature 20°C above the ambient temperature. Environmental connectors are supplied with the heater. An optional thermostat is also available.

Optional Heater Models	Description
20201	115 V AC
20201-A	230 V AC
10681	Heater Thermostat

2. INSTALLATION

This instrument is thoroughly tested and fully calibrated at the factory, and is ready for installation. Please refer to the return authorization card included in the packing box if damage has occurred. Also, notify All Weather Inc.

The wind vane unit is shipped complete with a tail assembly, counterweight, and mating electrical connector. The mating connector will be attached to the cable if cable was ordered. The vane will mount directly onto the Model 2023 Crossarm Assembly. The accessory Model 20231 Mast Adapter may be ordered to allow the vane to be mounted onto a 1" outside diameter mast.

2.1 ASSEMBLY

With the exception of installing the tail and counterweight, the Model 2020 Micro Response Vane is ready for mounting. The counterweight is generally shipped unattached, and is packed in the 2020 housing's packing carton. The tail is packed inside a folded cardboard container taped to the side of the 2020 carton. Install the tail and counterweight as explained in the steps below.

1. Slide the vane tail shaft into the vane hub, entering the hub at the side opposite the scribe mark. Do not tighten the set screw on the hub yet.

2. Install the counterweight, making certain the vane tail shaft is fully engaged. Tighten the counterweight set screw with a 1/16" Allen wrench.
3. Hold the vane in a horizontal position and slide the tail shaft through the hub until the counterweight exactly balances the tail and the vane does not turn when held in a horizontal position. When balance is achieved, tighten the hub set screw with a 1/16" Allen wrench, making certain the tail is aligned with the axis of the vane. This procedure must be performed in an area free of drafts and air currents.

2.2 SITE SELECTION

The location of the vane is critical for accurate wind measurements. The standard exposure of an anemometer or vane over open, level terrain is 10 meters above the ground. Open, level terrain is defined as level ground with no obstruction within 300 meters. In locations where obstructions are not large, such as residential areas, and are distributed more or less evenly, the vane may be placed at an effective height of $h + 10$ meters, where h is the approximate height (in meters) of the various obstacles. As an example, in a location where trees and buildings reach to about 5 meters, the vane must be placed on a 15 meter mast to avoid erroneous results.

Table 1 — Determining Minimum Height of Anemometer

Distance to Obstruction	Minimum Height Above Ground Level of Anemometer
h	$1.75h$ to $2.25h$
$5h$	$1.67h$
$10h$	$1.50h$
$20h$	$1.25h$
$25h$	$1.13h$
$30h$	h

Handbook of Meteorological Instruments, 2nd Edition. Measurement of Surface Wind, Volume 4. London, HMSO: 1981.

In areas where large obstructions exist within 300 meters of the anemometer or vane, the table on the preceding page can be used to calculate the proper height (h is the height of the obstruction).

Example: If there is a building 10 meters high and 50 meters away, the anemometer or vane should be at least 16.7 meters above the ground. But, if the same building is 200 meters away, the anemometer or vane could be lowered to 12.5 meters.

When the anemometer or vane is mounted on a building, the building itself disturbs the wind flow and must be taken into account before installation. For large buildings, other than buildings such as lighthouses and skyscrapers, the anemometer or vane must be mounted as far away from the edge of the building as possible and at a height **at least 3/4 the height of the building**. Thus, with a building 28 meters high, a rooftop tower at least 21 meters high should be used.

2.3 MOUNTING

The Model 2020 Micro Response Vane mounts directly to the Model 2023 Crossarm without any additional accessories. The crossarm is generally used to mount a Model 2030 Anemometer in combination with the Model 2020 Vane to form a wind speed and direction measurement set. If the Model 2020 Vane is to be mounted separately, a Model 20231 Mast Adapter should be ordered as an accessory. Both the Model 2023 Crossarm and the Model 20231 Mast Adapter will mount to a mast with an outside diameter of 1" (25.4 mm) or 3/4" Schedule 40 pipe.

For AWOS installations, refer to the **2020/2030 AWOS Mounting** figure in the *Drawings* chapter of this manual.

2.4 WIND DIRECTION BENCHMARK (AWOS INSTALLATIONS)

For AWOS installations, a wind direction reference point must be established in one of the four cardinal directions. It is simplest to use True North as the reference, though at some installations this may not be feasible. The following instructions explain how to locate a North benchmark. Any of the other three directions can be determined once True North has been established.

True North uses the earth's geographic meridians, while Magnetic North is the North indicated by a magnetic compass. Depending on a site's location, Magnetic North is to either the East or West of True North (with the exception of sites along the "line of zero declination", where Magnetic and True North are the same). This difference, measured in degrees, between True North and Magnetic North is known as the magnetic declination. For sites west of the line of zero declination (which runs roughly from west of Hudson Bay, down along Lake Michigan to the Gulf Coast in western Florida), the **magnetic declination** is "Easterly." For sites east of the zero line, the declination is "Westerly." Magnetic declination for a particular site can be obtained from the site survey data form, airport directory, or from any USGS map.

Use the Model 8297 Surveying Compass with Telescope to determine True North at the installation site. This instrument allows you to determine True North to within 1° accuracy.

Once True North has been established, use the Model 8297 compass/telescope to determine the location at which the benchmark will be installed. The benchmark should be aligned with the Model 2020 vane, approximately 100 feet from the tower. Set the marker using a bag of quick-set concrete at the determined location, and note the location in the log book.

2.5 ORIENTATION

The Model 2020 Micro Response Vane must be oriented correctly as to direction. The axis of the vane should be as close to vertical as possible. Orient the vane to direction (azimuth) as described in the steps below.

1. The crossarm and/or mast should be locked into the operating position. To aid in orientation, the crossarm can be set in a North-South orientation using the mounting pins as targets.
2. Install the vane on the mast adapter with the dowel pin aligned with the mating hole in the vane housing. Once alignment is properly attained, the housing will slide onto the adapter. An identical dowel pin arrangement is found on the crossarm.

3. Tighten the clamp screw at the base of the vane. Align the scribe mark on the body with the scribe mark on the hub by rotating the hub and tail assembly. Hold the two marks in alignment. An easy way to accomplish this task is to use the Model 1249-A Wind Direction Calibrator.
4. Loosen the clamp set screw at the end of the crossarm to allow the vane and pin to turn as a unit. Loosen the mast set screws on the mast adapter.
5. Using a reference point with a transit or compass, rotate the vane body until the nose points to true North. Tighten the cap screw on the crossarm clamp or the set screws on the mast adapter. Remove the calibrator from the vane hub and body to allow free rotation of the tail.

When removing the vane assembly, do not disturb the position of the pin on the crossarm; when using a mast adapter, do not move the adapter. This will allow you to remove and reinstall the vane without repeating the orientation procedure.

2.6 CONNECTION

Install a three-wire 20 AWG cable in the mating connector using care in soldering and cable dressing. Replace the connector back shell to form a waterproof assembly. The connector is a quick release type and requires only a quarter turn of the nut to lock it in place. Do not tighten with a wrench. Connections are as shown in drawing 2020-004 at the back of this manual. If cable is ordered with the vane, the connector will be attached at the factory. To order cable, specify part number T600503.

3. THEORY OF OPERATION

3.1 DEFINITION

Wind direction is defined as the direction of the source of the wind flow measured in degrees from true North in a clockwise increasing angle. Example: A west wind (270°) originates in the West and moves in an eastward direction.

3.2 THEORY OF OPERATION

Changes in wind direction are sensed mechanically by a balanced vane assembly. The mechanical motion is transformed into an electrical signal through a shaft coupling the vane to a potentiometer. The potentiometer is a $5\text{ k}\Omega$ conductive plastic resistive element with a long electrical angle.

Protective zener diodes are attached across the excitation lead and the wiper lead to the common lead to help quench transients induced by external sources.

The potentiometer is excited by a $+5\text{ V DC}$ regulated source. A $2500\ \Omega$ resistor is placed in series with the $+5\text{ V DC}$ source to protect the potentiometer element against a dead short in the $+5\text{ V DC}$ power source. The voltage generated at the potentiometer wiper varies from $0\text{--}3.333\text{ V DC}$ as a direct function of wind direction variations.

4. CALIBRATION

Refer to the appropriate signal conditioning manual for system calibration instructions. Check the Model 2020 Micro Response Vane for correct operation prior to making any adjustments to the system electronics.

4.1 CHECKING VANE OPERATION

To check vane operation, follow the steps below.

1. Measure the total resistance of the potentiometer by measuring the resistance between the white wire (+) and the black wire (-). The value should be $5000\ \Omega$, $\pm 5\%$.
2. Use a voltmeter to measure the voltage across the potentiometer. ***Use Caution—Observe the polarity of the test leads.*** Using the cable supplied, place the (+) test probe onto the red wire and the (-) test probe onto the black wire. Rotate the vane in a clockwise direction (as viewed from the top). The voltage should increase as the vane is rotated.

4.2 ALIGNMENT

Align the potentiometer with the North alignment marks on the vane housing by rotating the potentiometer body while monitoring the voltage output. Since the vane hub is not flush with the vane body, be sure to view the alignment marks from straight on to avoid parallax errors.

1. Loosen the two clamping screws on the potentiometer mounting plate.
2. Align the tail assembly to South. The two North marks will be 180° apart.
3. While holding the North alignment marks stationary, rotate the potentiometer body until the signal output reads 1.6665 V DC (one half the total voltage across the potentiometer).
4. Tighten the clamping screws and re-measure the output to check for changes during tightening of the screws. Repeat Step 3 if necessary.

Verify the operation of the vane before reinstalling it. Always verify its operation after each realignment and especially after any service requiring disassembly of the housing is performed.

CALIBRATION CERTIFICATE

Instrument Micro Response Vane

Model Number 2020 Serial Number _____

Range	Calibration Points	Output (typical)	Output (actual)
1-360° Azimuth	180° AZ	1.665 V DC*	

* with excitation voltage of 3.333 V DC

Cable T600503 Length _____ Shield Yes No

Refer to enclosed Calibration Sheet. Figure _____

Must be used in conjunction with:

Instrument _____

Model Number _____ Serial Number _____

Technician _____ Date _____

5. MAINTENANCE

Routine maintenance must be performed on the vane to prevent severe corrosion build-up and to check its bearings and operation.

5.1 CHECKING THE BEARINGS

The vane shaft coupled to the potentiometer should turn freely at all times. Rough motion indicates worn bearings either in the potentiometer or in the vane body. Determine which bearings are faulty by decoupling the potentiometer from the main shaft.

Replace the bearings as required. The potentiometer is not serviceable and must be replaced if the bearings are faulty or the resistive element is worn.

5.2 PRECAUTIONS

Since corrosion is the main problem associated with all wind sensors, apply a thick coating of silicon lubricant to the connector shell after the connector is attached and in place. Also, use a noncorrosive lubricant such as Loctite Silver Grade Anti-Seize Compound on all screws and fasteners whenever disassembly of the vane is required. The use of these lubricants will make servicing of the vane easier and will prevent seizure of the fastening hardware. It is also advisable to apply lubricant to the mounting adapter surfaces prior to final vane installation. A commercial grade lubricant recommended for use is DOOR-EASE, available at hardware and automotive stores. In addition to these precautions, check that the drain hole in the base of the vane body is free of debris so that water drains away rather than collecting within the body.

Use great care in disassembly and reassembly of the vane and vane body. Never use excessive force to make parts fit together. Overtightening of fasteners will either break the fastener or damage the machined threads.

Any difficulties encountered during servicing that are not correctable by the user should be referred to the All Weather Inc. Customer Service Department.

5.3 REPLACING THE BEARINGS

Follow the steps below to replace the bearing in the field.

1. Remove the Allen-head set screw securing the vane body cap to the main shaft using a 1/16" Allen wrench, and lift off the vane and vane body cap as a unit.
2. Lift the upper bearing out by working a knife edge under the flanged outer race.
3. Clean all parts and install a new bearing. Press the bearing in place by applying pressure to the outer race only. The bearing could be damaged by pressing against the inner race.
4. Reassemble all parts in the reverse order of disassembly. Check for free and smooth rotation of the shaft before and after installing the vane assembly.

5.4 DISASSEMBLY AND POTENTIOMETER REPLACEMENT

The potentiometer must be unsoldered from the housing connector before it can be removed from the housing. Refer to Drawing 2020-003 for parts identification as needed while following the steps below.

1. Remove the Allen-head set screw securing the vane body cap to the main shaft, and lift off the vane and vane body cap as a unit.
2. Remove the three screws from the base of the housing and remove the base.
3. Remove the two screws and flat washers securing the potentiometer inside the housing and gently lower the potentiometer and shaft.

5.5 MAINTENANCE KIT

A maintenance kit (P/N M488140) is available for the Model 2020 that provides the parts necessary for basic upkeep of the instrument. The kit includes those parts that are the most susceptible to wear, such as bearings and set screws. To order this kit, contact All Weather Inc. and specify Part Number M488140.

5.6 PERIODIC MAINTENANCE

Periodic maintenance is divided into three categories: monthly maintenance, triannual maintenance, and annual maintenance. The listed maintenance routines are performed according to that schedule.

You will need the following equipment and supplies.

- Compass or transit
- ½" wrench
- Silicon lubricant
- Noncorrosive lubricant (bee's wax)

5.6.1 Monthly Maintenance

Monthly maintenance of the Model 2020 vane consists of visually verifying that the vane is moving freely and that the displayed wind direction is reasonable compared to the orientation of the vane.

5.6.2 Triannual Maintenance

The triannual maintenance procedure for the Model 2020 vane is identical to the monthly maintenance procedure: visually verify that the vane is moving freely and that the displayed wind direction is reasonable compared to the orientation of the vane.

5.6.3 Annual Maintenance

During annual maintenance, perform the following procedures in addition to those outlined for monthly and triannual maintenance.

1. Remove the vane from the mounting bracket by loosening the clamp screw located at the base of the unit. Leave the cable connected and, if present, also leave the heater cable connected. These cables will ensure that the vane will not fall if it is dropped.

2. Clean the drain hole on the bottom of the vane body to ensure that debris does not prevent water from draining out of the vane.
3. Spread noncorrosive lubricant such as Loctite Silver Grade Anti-Seize Compound on the clamp screw and reinstall the vane. The vane mounting hole should be aligned with the pin on the base of the mounting bracket.
4. Rotate the vane slowly through a full 360°, noting the reading on the display. As the vane is turned, the displayed values should change smoothly, with no sudden jumps or dropouts. Note, however, that there is a 10° dead band at North where suspicious readings are likely to be seen. This behavior is normal near North, but in any other direction indicates a potentiometer failure.

If the vane fails any part of this test, replace the vane.
5. Verify that the vane's movement is free and smooth. If it is not, replace the bearings. The shaft should turn freely at all times.
6. Inspect all mounting hardware and cable assemblies for wear and damage. Replace as necessary.
7. Apply a thick coating of silicon lubricant to the connector shell after the connector is attached and in place. Use a noncorrosive lubricant such as bee's wax on all screws and fasteners whenever disassembly is required. The use of these lubricants will make future servicing easier.
8. If heaters are installed, verify that they are working by holding your hand close to the heater. The heater is always on, and should be warm.

5.6.4 Verify Alignment Annually

The *AWOS 3000 Maintenance Manual* (3000-027) describes how to verify the alignment of a Model 2020 vane that is installed as part of an AWOS 3000 system, including variations in the procedures between foldover and stationary towers.

The instructions in this section can be used to verify the vane alignment in other applications.

You will need the following equipment.

- Model 1249-A Wind Direction Calibrator
- M104869-A Calibration Shaft

1. Locate the direction benchmark determined in the initial site survey. It should be approximately 100 to 150 feet from where the Model 2020 vane is installed in one of the four cardinal points referenced to true north.
 2. Separate the two halves of the Model 1249-A Wind Direction Calibrator by pulling the two discs apart.
 3. Slip the bottom half of the calibrator (containing the knurled knob) onto the stationary portion of the vane's housing near the rotating cap. Loosen the knob, if necessary, to do this; then tighten the knob until the unit is secured.
 4. Slide the M104869-A calibration shaft into the hub.
 5. Hold the vane's tail shaft and place the top half of the calibrator onto the shaft and vane body cap. Notice that the top half is recessed to accommodate the counterweight, and that there is a groove for the tail shaft and a cutout for the top of the vane cap.
 6. The top piece has four shafts, which should set in the four holes on the lower piece. Raise the calibrator on the Model 2020 vane shaft so that the top piece does not have any weight on the calibration shaft, but the shaft is still in the groove. Line up the scribe marks on the hub and lower body of the Model 2020 vane, and tighten the knob to secure the calibrator to the vane in the North position.
- Note that the two people may be needed to perform the remaining steps when the Model 2020 vane is some distance away from where the data are displayed.*
7. While observing the data display, loosen the knurled knob slightly and rotate the entire calibration unit (along with the vane tail) until the display indicates 180°. (If the benchmark is located to the East or West, rather than to the North or South, rotate the vane until the display reads 90 or 270.) Securely tighten the knurled knob to hold the vane in this position.
 8. With the vane locked in position, stand at the direction benchmark and verify that the tail of the vane is aligned with the vane body. If the vane is not aligned, loosen the mounting screw located at the bottom of the unistrut, align the vane (and base) with the benchmark, and tighten the mounting bolt.
 9. Lift the top half of the calibrator and rotate it and the vane tail 90° to the next position. Verify that the display agrees with the new direction. Continue rotating the vane to each of the remaining cardinal directions and verify that the vane position and display agree.
- If the display does not match the vane position, replace the Model 2020 vane.*
10. Remove the calibrator.

6. WARRANTY

Unless specified otherwise, All Weather Inc. (the Company) warrants its products to be free from defects in material and workmanship under normal use and service for one year from date of shipment, subject to the following conditions:

- a. The obligation of the Company under this warranty is limited to repairing or replacing items or parts which have been returned to the Company and which upon examination are disclosed, to the Company's satisfaction, to have been defective in material or workmanship at time of manufacture.
- b. The claimant shall pay the cost of shipping any part or instrument to the Company. If the Company determines the part to be defective in material or workmanship, the Company shall prepay the cost of shipping the repaired instrument to the claimant. Under no circumstances will the Company reimburse claimant for cost incurred in removing and/or reinstalling replacement parts.
- c. The warranty shall not apply to any Company products which have been subjected to misuse, negligence, or accident.
- d. This warranty and the Company's obligation thereunder is in lieu of all other warranties, express or implied, including warranties of merchantability and fitness for a particular purpose, consequential damages, and all other obligations or liabilities.

No other person or organization is authorized to give any other warranty or to assume any additional obligation on the Company's behalf, unless made in writing and signed by an authorized officer of the Company.

7. SPECIFICATIONS

Parameter	Specification
Operating Temperature	-40 to +60°C (-40 to +140°F)
Sensor Type	Rotating vane
Transducer	Potentiometer, 5000 Ω , single wiper
Threshold	0.8 km/h (0.5 mph)
Dead Band	5.0° at 0°
Resolution	Less than 1.0°
Distance Constant	1.07 m (3.5 ft)
Damping Ratio	0.4
Potentiometer Linearity	0.5%
Bearing	Sealed stainless steel with synthetic lubricant
Turning Radius	457 mm (18")
Mounting	Direct to crossarm or with adapter to 1" (2.5 cm) O.D. mast
Body Size	30.5 cm H \times 7 cm diameter (12" H \times 2¾" diameter)
Weight	1.1 kg (2.5 lb)
Shipping Weight	3.2 kg (7 lb)

Optional heaters available

8. DRAWINGS

The following pages include reference drawings to assist in installation and maintenance of this instrument.

M403256-01-003 (2 sheets)	2020/2030 Crossarm Assembly Mounting Drawing
2020-003 (2 sheets)	Assembly Drawing, 2020 Vane Sensor Body
2020-004	2020 Schematic

REVISIONS			DWG NO. M403256-01-003	
REV	ECO	DESCRIPTION	DATE	APPROVED
A	1281	INITIAL RELEASE	10/24/07	BRG
B	3874	ADDED ICE-FREE HUB TO 2020 WIND VANE	12/31/14	T. IWANOWSKI

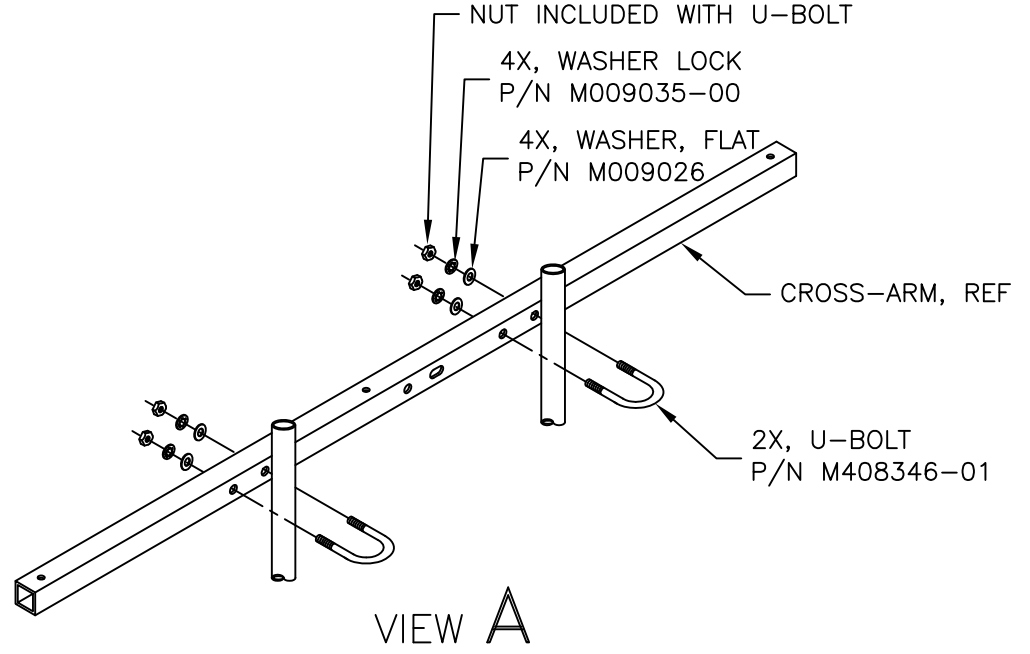
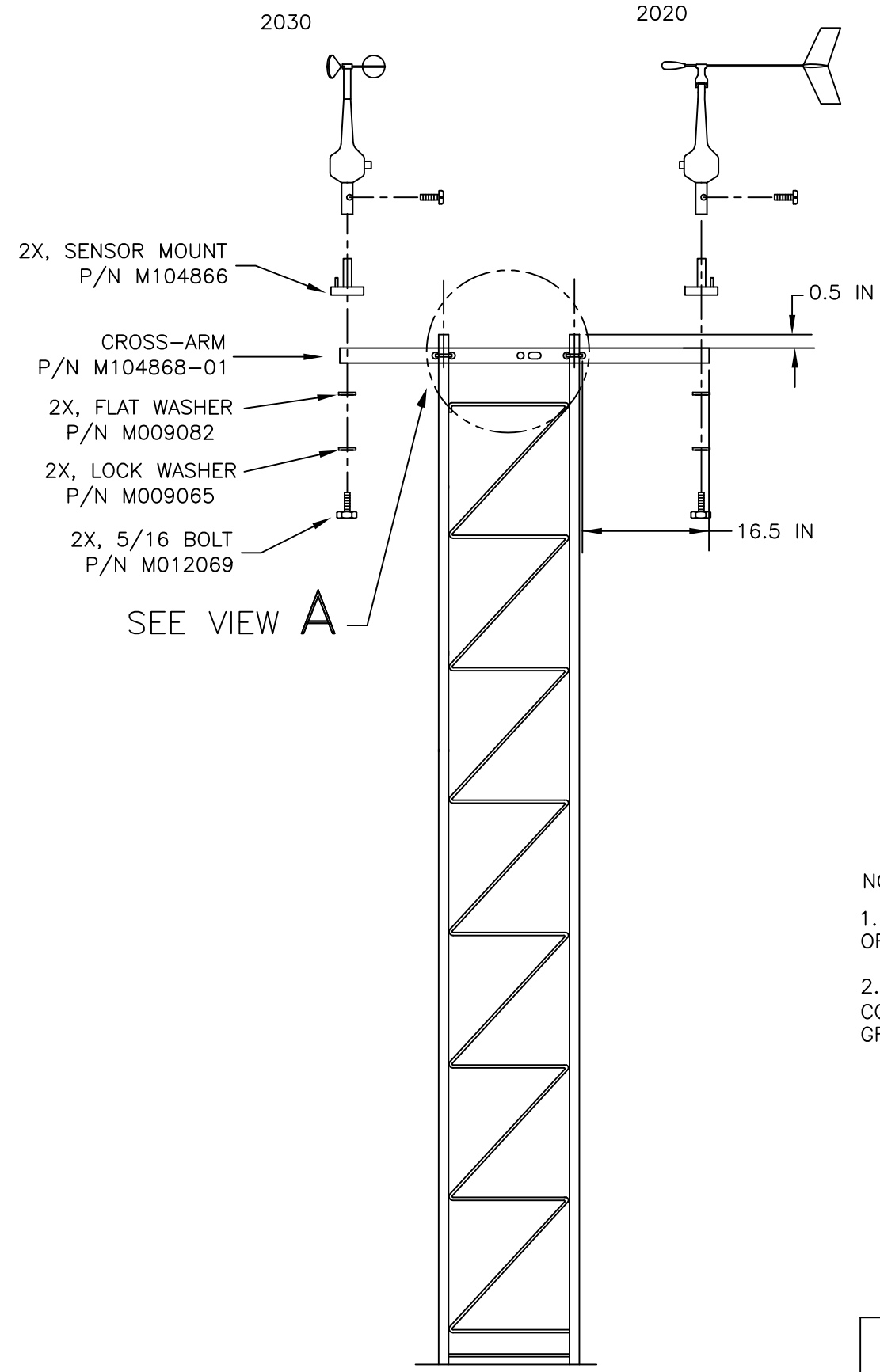

2020/2030
AWOS MOUNTING
(STACKED TOWER)

NOTES: UNLESS OTHERWISE SPECIFIED:

1. APPLY LOCTITE SILVER GRADE ANTI-SEIZE COMPOUND (M401065-00) OR EQUIVALENT TO ALL EXTERNAL THREADED CONNECTIONS.
2. AFTER INSTALLATION IS COMPLETE, APPLY A LIGHT SPRAY OF CORROSION BLOCK (M402010-00) TO ALL METALLIC CONNECTORS, GROUND LUGS AND THREADED FASTENERS.

EXCEPT AS MAY OTHERWISE BE SPECIFIED BY CONTRACT, THIS DOCUMENT AND THE DATA DISCLOSED HEREIN AND HERewith, IS NOT TO BE USED, REPRODUCED OR DISCLOSED, IN WHOLE OR IN PART, TO ANYONE WITHOUT THE WRITTEN PERMISSION OF ALL WEATHER INC.

B	B	REV	REV STATUS
2	1	SHEET	OF SHEETS

UNLESS OTHERWISE SPECIFIED: DIMENSIONS ARE IN INCHES TOLERANCES XX=±.010 ANGLES ±1/2' XXX=±.005 FRACTIONS=±.02 DO NOT SCALE DRAWING	DRAWN BY: B. GALARPE	10/24/07	TITLE ASSEMBLY DRAWING, CROSSARM, 2020, 2030, AWOS, CORROSION RESISTANT		
	MATL SEE PARTS LIST	REVISOR BY:			
	FINISH AS ISSUED	CHECKED BY: -			-
	TREATMENT	DESIGN ENGINEER: J. CONNER			-
	PROGRAM MANAGER: -	-	SIZE C	DWG NO. M403256-01-003	
APPROVALS	DATE	SCALE NONE	RELEASE DATE -	SHEET 1 OF 2	

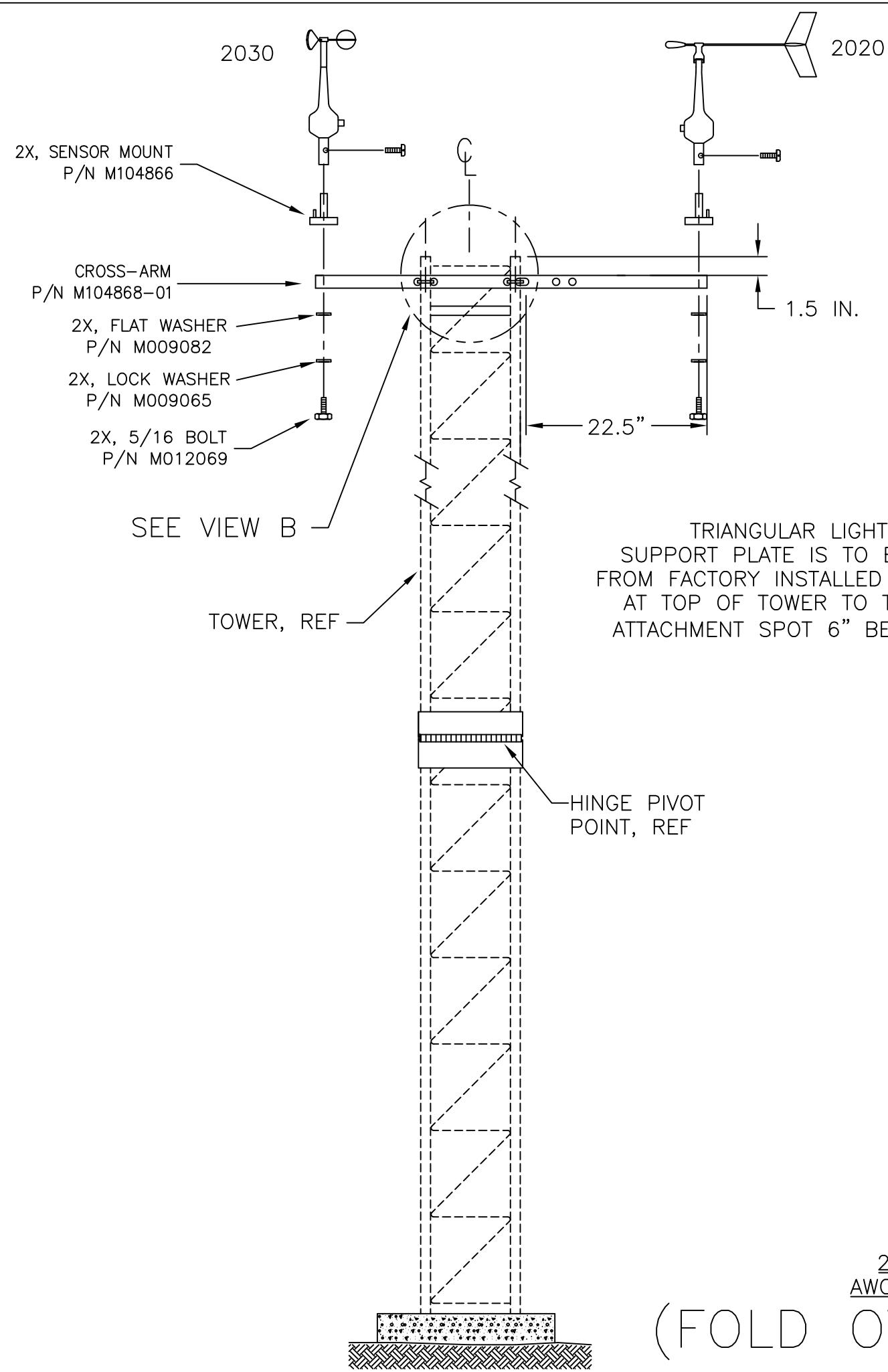

2X, SENSOR MOUNT
P/N M104866

CROSS-ARM
P/N M104868-01

2X, FLAT WASHER
P/N M009082

2X, LOCK WASHER
P/N M009065

2X, 5/16 BOLT
P/N M012069

SEE VIEW B

TOWER, REF

HINGE PIVOT
POINT, REF

***NOTE:**
TRIANGULAR LIGHTNING ROD
SUPPORT PLATE IS TO BE MOVED
FROM FACTORY INSTALLED LOCATION
AT TOP OF TOWER TO THIS NEXT
ATTACHMENT SPOT 6" BELOW TOP.

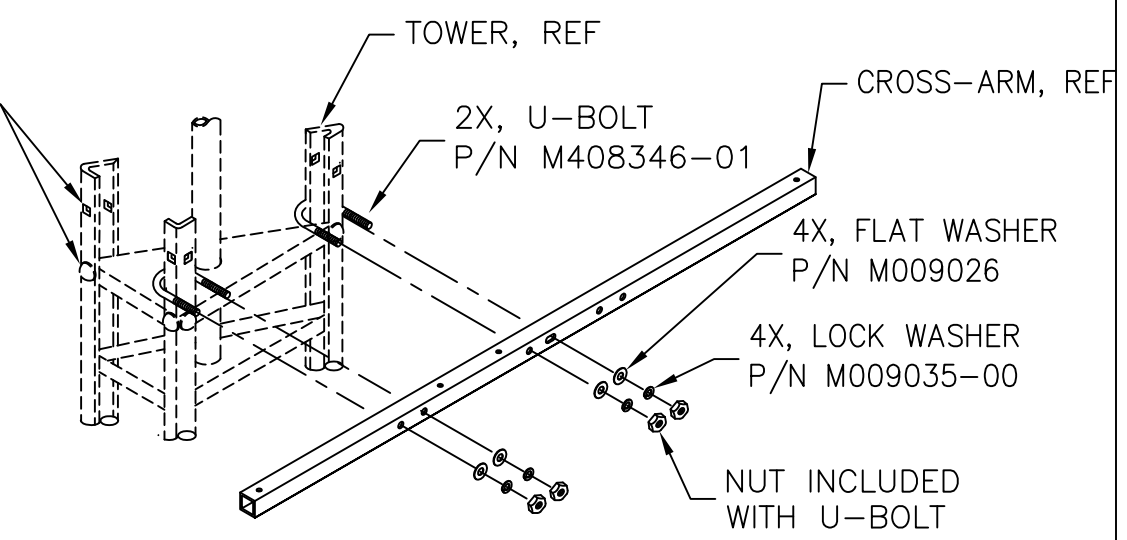

VIEW B

2020/2030
AWOS MOUNTING
(FOLD OVER TOWER)

EXCEPT AS MAY OTHERWISE BE SPECIFIED BY CONTRACT,
THIS DOCUMENT AND THE DATA DISCLOSED HEREIN
AND HERewith, IS NOT TO BE USED, REPRODUCED OR
DISCLOSED, IN WHOLE OR IN PART, TO ANYONE WITHOUT
THE WRITTEN PERMISSION OF ALL WEATHER INC.

SIZE	DWG NO.			
C	M403256-01-003			
SCALE	REV LTR	A	SHEET	2 OF 2

REV ECN		REVISIONS	DATE	APPROVED
A		INITIAL RELEASE	12-21-92	
B 4225		NEW DESIGN OF IT-17, DELETE IT-19	5-17-93	PS
C 4538		DELETE ITEM 3, ADDED NOTE 10 & 11 ADD IT-19 & 20, DELETE NOTE 8	21NOV95	KAH
D 4738		ADD CE LABEL IT-21 & NOTE 12		
E 5016		DEL IT-13 & SHOW AS P/O IT-15, DEL NOTE 4	4/03	PK
F 5095		REVISED NOTE 6, ADD NOTE 6 TO ITEM 9 (3X)	9-13-04	J.CONNER
G 5152		ADD NOTE 13	12-13-04	J.CONNER
H 1369		REVISED ITEM 16	12-18-07	J.CONNER

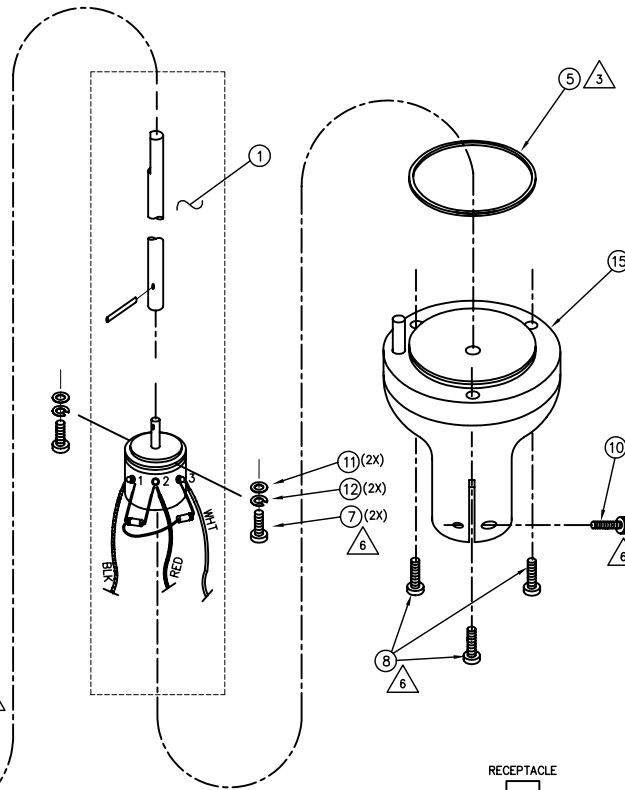
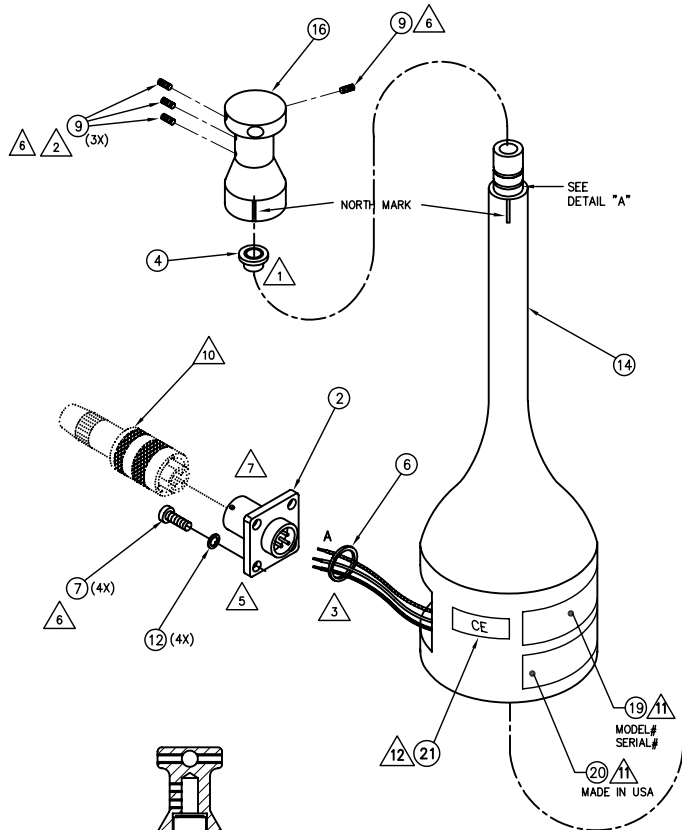

- NOTES: UNLESS OTHERWISE SPECIFIED
1. SECURE BEARING (ITEM 4) TO UPPER BODY (ITEM 14) WITH "LOCKTITE" 222. DO NOT ALLOW "LOCKTITE" TO CONTAMINATE WORKING SURFACES OF BEARING.
 2. WHEN INSTALLING HUB, (ITEM 16) INSURE THAT SCREWS (ITEM 9), ALIGN WITH FLAT AREA OF SHAFT (PART OF ITEM 1).
 3. APPLY SILICONE GREASE TO O-RING.
 4. DELETED
 5. SOLDER WIRES FROM POT/SHAFT ASSY (ITEM 1) TO RECEPTACLE (ITEM 2). APPLY LIQUID "HUMISEAL" OR EQUIV. TO SOLDER CONNECTIONS.
 6. COAT SCREW THREADS WITH ANTI-SEIZE COMPOUND, LOCTITE SILVER GRADE, ANTI-SEIZE, OR EQUIV.
 7. INSTALL RECEPTACLE (ITEM 2) TO UPPER BODY (ITEM 14) WITH LARGE KEY WAY OF RECEPTACLE TOWARD TOP OF ASSEMBLY.
 8. DELETED
 9. SEE 2020-001 FOR VANE AND COUNTER WEIGHT ASSEMBLY (SECTIONS 3.3 THRU 3.7) NOT FACTORY INSTALLED.
 10. MATING CONNECTOR, T210001, NOT INCLUDED IN THIS ASSEMBLY.
 11. INSTALL LABELS OPPOSITE RECEPTACLE. IDENTIFY AS MODEL 2020 AND SERIALIZE.
 12. AFFIX 1/2" SQUARE BLACK-ON-SILVER CE LABEL (ITEM 21) AS SHOWN.
 13. AFTER ASSEMBLY IS COMPLETE, BOX THE SENSOR BODY IN A 15 3/4 X 3 1/4 X 3 1/4 BI-PANEL FOLDED CARDBOARD BOX. OBTAIN BOXES FROM SHIPPING.

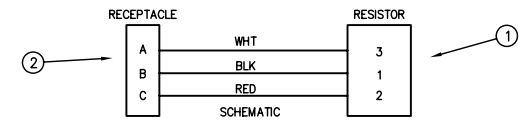
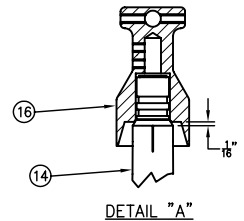

EXCEPT AS MAY OTHERWISE BE SPECIFIED BY CONTRACT, THIS DOCUMENT AND THE DATA DISCLOSED HEREIN AND HERETHWITH, IS NOT TO BE USED, REPRODUCED OR DISCLOSED, IN WHOLE OR IN PART, TO ANYONE WITHOUT THE WRITTEN PERMISSION OF ALL WEATHER INC.

D	H	REV	REV STATUS
2	1		OF SHEETS

APPEND THE FOLLOWING DOCUMENTS WHEN CHANGING THIS DOCUMENT: 2020-001		UNLESS OTHERWISE SPECIFIED: DIMENSIONS ARE IN INCHES TOLERANCES XX=.010 ANGLES ±1/2" XXX=±.005 FRACTIONS=±.02 DO NOT SCALE DRAWING		DRAWN BY: PETE SANCHEZ 15DEC92		TITLE ASSEMBLY DRAWING, MICRO RESPONSE VANE SENSOR BODY	
MATERIAL SEE BILL OF MATERIALS		FINISH AS ISSUED		REVISOR BY: P KOOYMAN 29mar04		allweatherinc	
DESIGN ENGINEER: ALEX TACKETT 16DEC92		PROJECT MANAGER: JM ANDERSON 16DEC92		APPROVALS		DATE	
SCALE NONE		RELEASE DATE 12-21-92		SHEET 1 OF 2		D 2020-003	

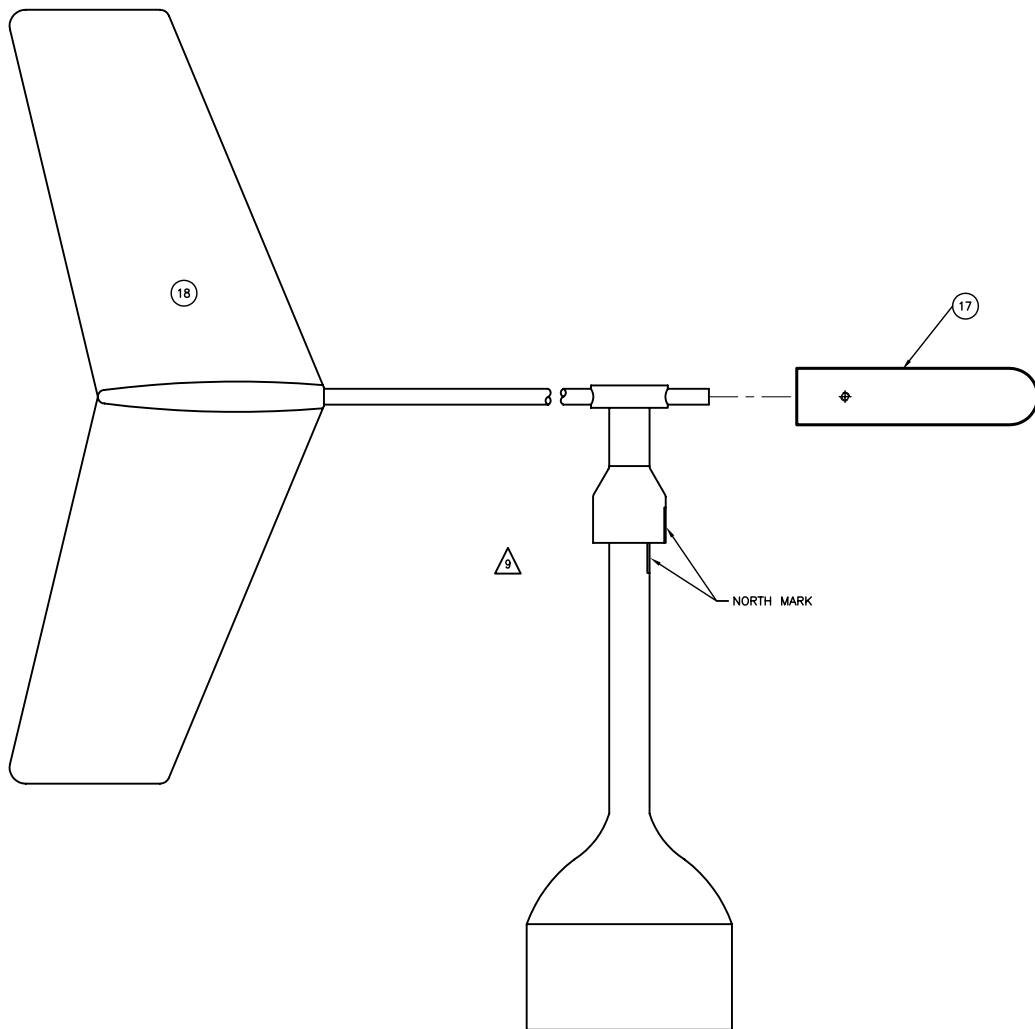

EXCEPT AS MAY OTHERWISE BE SPECIFIED BY CONTRACT,
THIS DOCUMENT AND THE DATA DISCLOSED HEREIN
AND HEREWITH, IS NOT TO BE USED, REPRODUCED OR
DISCLOSED, IN WHOLE OR IN PART, TO ANYONE WITHOUT
THE WRITTEN PERMISSION OF ALL WEATHER INC.

REVISIONS			2020-004	
REV	ECN	DESCRIPTION	DATE	APPROVED
A	2468	SEE ECN HISTORY	3JAN86	
B	4101	INCREMENT REV. TO TRACK	14DEC92	
C	4153	ADD 1,2,3 & ADD WHT, RED, BLK	12-2-92	
D	4538	UPDATED ECN 4538 ONLY		

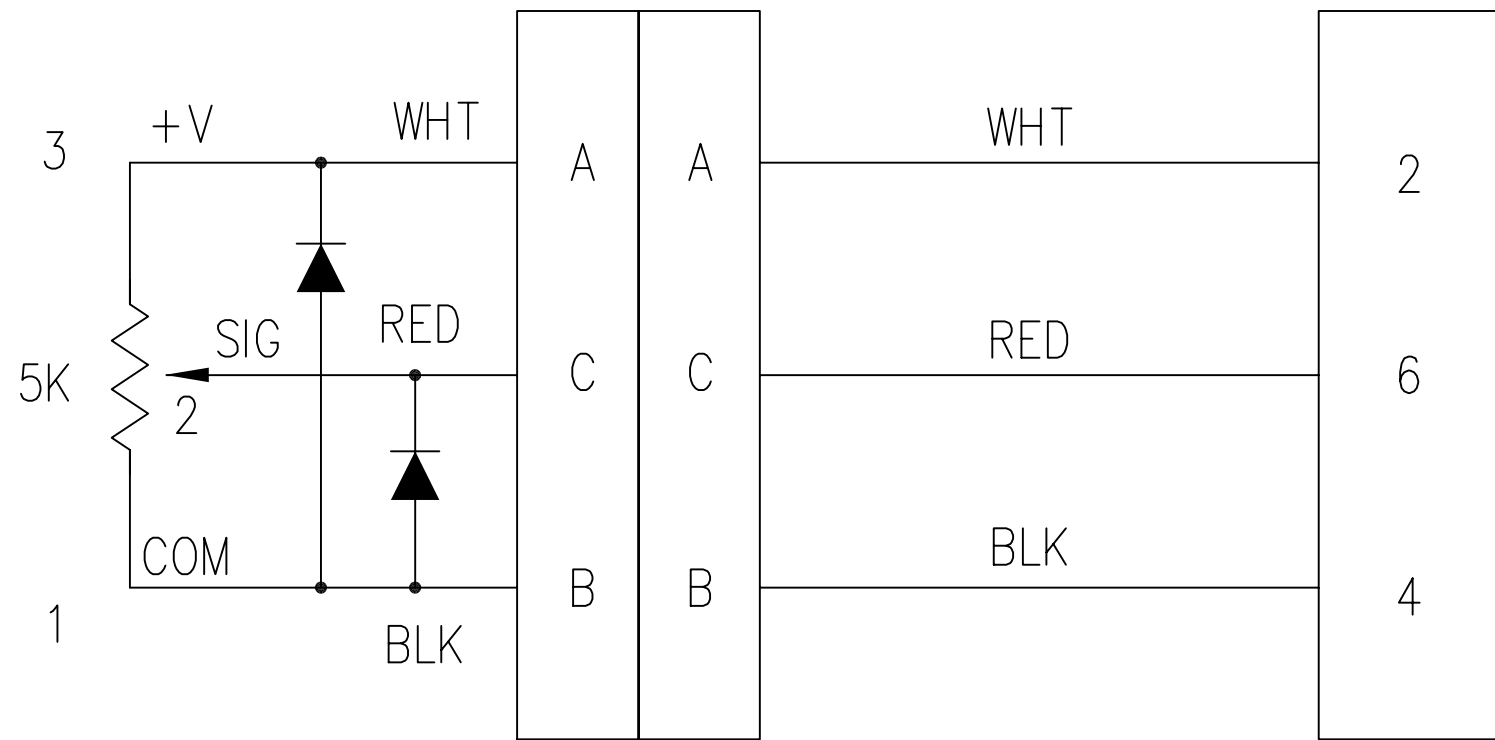

3 PIN
CONNECTOR

MODEL
TERMINAL BLOCK
PIN NO.

EXCEPT AS MAY OTHERWISE BE SPECIFIED BY CONTRACT,
THIS DOCUMENT AND THE DATA DISCLOSED HEREIN
AND HERewith, IS NOT TO BE USED, REPRODUCED OR
DISCLOSED, IN WHOLE OR IN PART, TO ANYONE WITHOUT
THE WRITTEN PERMISSION OF QUALIMETRICS, INC..

APPEND THE FOLLOWING
DOCUMENTS WHEN CHANGING
THIS DOCUMENT:

2020-001	

UNLESS OTHERWISE SPECIFIED:
DIMENSIONS ARE IN INCHES
TOLERANCES
XX=±.010 ANGLES ±1/2°
XXX=±.005 FRACTIONS=±.02
DO NOT SCALE DRAWING

MATL
SEE BILL OF MATERIALS
FINISH
AS ISSUED
TREATMENT

DRAWN BY:
PETE SANCHEZ 25JUNE92
REVISED BY:
J CONNER 12SEP95
CHECKED BY:
DESIGN ENGINEER:
PROJECT MANAGER:
APPROVALS DATE

TITLE
SCHEMATIC
MICRORESPONSE VANE



SIZE A DWG NO. 2020-004

SCALE NONE RELEASE DATE SHEET 1 OF 1



All Weather Inc.
1165 National Drive
Sacramento, CA 95834
USA
800.824.5873
www.allweatherinc.com

2020-001
January, 2015
Revision P